



Contents

1.	Information on This Operating Instruction	1
1.1	Pictographs Used	2
1.2	Exclusion of Liability	2
1.3	General Information	2
2.	Safety Instructions	2
3.	Device Description	3
3.1	Resilient Elements, Construction Types of Pressure Gauges and Chemical Seals	3
3.1.1	Resilient Elements	3
3.1.2	Construction Types Pressure Gauges	4
3.1.3	Construction Types Chemical Seals	5
4.	Selection Criteria	6
4.1	Measuring Principles	6
4.2	Pressure Ranges	7
4.3	Error Limits	7
4.4	Operating Conditions	7
4.4.1	Medium Properties, Pressure Profile	7
4.4.2	Ambient Conditions	8
5.	Additional Accessory	9
6.	Measuring Arrangements	10
7.	Installation	11
8.	Intended Use	12
9.	Additional Accessories	13
9.1	Electrical Limit Switch Contact Assemblies	13
9.2	Pneumatic Limit Switch Contact Assemblies	14
9.2.1	Operating Principle	14
9.2.2	Adjusting the Limit Setting Pointers	15
10.	Installation in Potentially Explosive Areas	15
10.1	General Information	15
10.2	Marking for the Explosion Hazardous Area	16
11.	Maintenance / Cleaning, Handling and Transport, Storage	16
12.	Dismounting and Disposal	17
13.	CE Conformity	18
14.	Declarations of Conformity	19

1. Information on This Operating Instruction

- The manual is aimed at specialists and semi-skilled personnel.
- Please read the instructions carefully before carrying out any operation and keep the specified order.
- Thoroughly read and understand the information in chapter 2 "Safety Instructions".

If you have any problems or questions, please contact your supplier or contact us directly at:



ARMANO Messtechnik GmbH **Location Beierfeld**

Am Gewerbepark 9 • 08344 Grünhain-Beierfeld
Tel.: +49 3774 58 – 0 • Fax: +49 3774 58 – 545
mail@armano-beierfeld.com

Location Wesel

Manometerstraße 5 • 46487 Wesel-Ginderich
Tel.: +49 2803 9130 – 0 • Fax: +49 2803 1035
mail@armano-wesel.com

1.1 Pictographs Used

In this manual, pictographs are used as hazard warnings.

Particular information, instructions and restrictions designed for the prevention of personal or substantial property damage:



WARNING! Is used to warn you against an imminent danger that may result in personal injury or death.

IMPORTANT! Is used to warn you against a possibly hazardous situation that may result in personal, property or environmental damage.

CAUTION! Is used to draw your attention to important recommendations to be observed. Disregarding them may result in property damage.



Passages in the text containing **explanations, information or advice** are highlighted with this pictograph.



The following symbol highlights **actions** you have to conduct or **instructions** that have to be strictly observed.

1.2 Exclusion of Liability

We accept no liability for any damage or malfunction resulting from incorrect installation, inappropriate use of the device or failure to follow the instructions in this manual.

1.3 General Information

Please inspect the transport packaging and the delivered items immediately upon their receipt to determine their integrity and completeness.

You have purchased an instrument that was manufactured according to high quality standards in our company, which is certified according to DIN ISO 9001.

The following manual was composed with due care. It is not possible, however, to take into account all versions and possible cases of application in this operating instruction. If you have any questions regarding a special application, instruments, storage, mounting, operation or difficulties, please contact us as manufacturer or the distributor.

Please support us in improving this operating instruction. We will gladly accept your advice.

2. Safety Instructions



IMPORTANT! Disregarding the respective regulations may result in severe personal injuries and / or property damage.

Please read this operating instruction thoroughly before installing the device.

Disregarding the containing warnings, especially the safety instructions, may result in danger for people, the environment, and the device and the system it is connected to.

The device corresponds with the state of engineering at the time of printing. This concerns the accuracy, the operating mode and the safe operation of the device.

In order to guarantee that the device operates safely, the operator must act competently and be conscious of safety issues.

The ARMANO Messtechnik GmbH provides support for the use of its products either personally or via relevant literature. The customer verifies that our product is fit for purpose based on our technical information. The customer performs customer and application specific tests to ensure that the product is suitable for the intended use. With this verification, all hazards and risks are transferred to our customers. Our warranty expires in case of inappropriate use.

Qualified personnel:

- The personnel that is charged for the installation, operation and maintenance of the instrument must hold a relevant qualification. This can be based on training or relevant tuition. The personnel must be aware of this manual and have access to it at all times.
- The electrical connection shall be carried out by a fully qualified electrician only.

General safety instructions:

- In all work, the existing national regulations for accident prevention and safety at the workplace must be complied with. Any internal regulations of the operator must also be complied with, even if these are not mentioned in this manual.
- Use the instrument in its perfect technical condition only. Damaged or defective instruments need to be checked immediately and replaced if necessary.
- Only use appropriate tools for mounting, connecting and dismantling the device.
- Nameplates or other information on the device shall neither be removed nor obliterated, since otherwise any warranty and manufacturer responsibility expires.
- In order to ensure measurement accuracy and durability of the instrument and to avoid damage, the limit values indicated in the technical data have to be observed.
- In case of visible damage or malfunctions, the instrument must be put out of operation immediately.
- Excessive heat (e.g. during or after external fire), especially on soldered joints, may cause leakage of the medium, which in turn can cause serious hazards. After an external fire, all instruments have to be checked before recommissioning the system and have to be replaced if necessary.

Special safety instructions:

Warnings, which are specifically relevant to individual operating procedures or activities, are to be found at the beginning of the relevant sections of this operating instruction.

3. Device Description

The information provided in this operating instruction, concerning selection, application, measuring arrangements, installation and operation, applies to pressure measuring instruments with an elastic measuring element.

3.1 Resilient Elements, Construction Types of Pressure Gauges and Chemical Seals

3.1.1 Resilient Elements

Resilient elements with Bourdon tube:

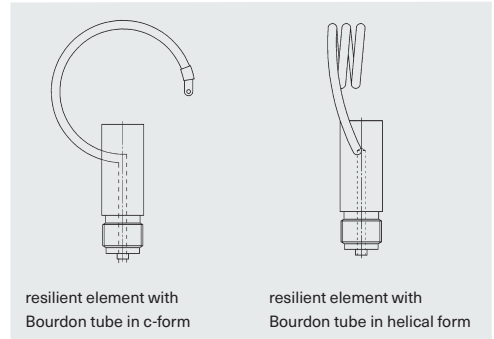

Resilient elements with diaphragm:

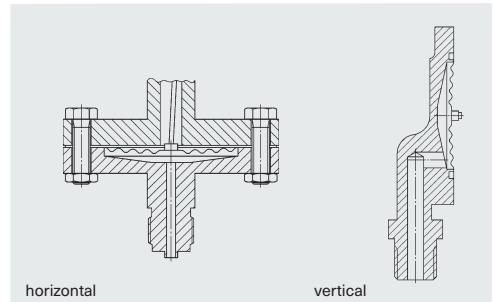

Resilient elements with diaphragm capsule:

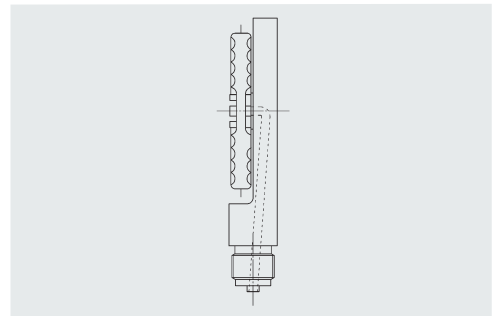

3.1.2 Construction Types Pressure Gauges

Pressure gauge with c-form Bourdon tube:

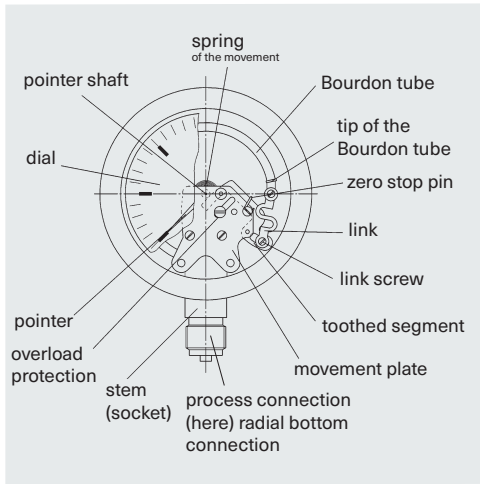

Pressure gauge with horizontal diaphragm:

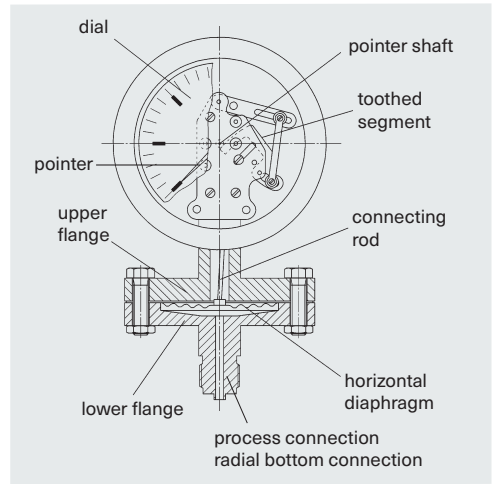

Pressure gauge with diaphragm capsule:

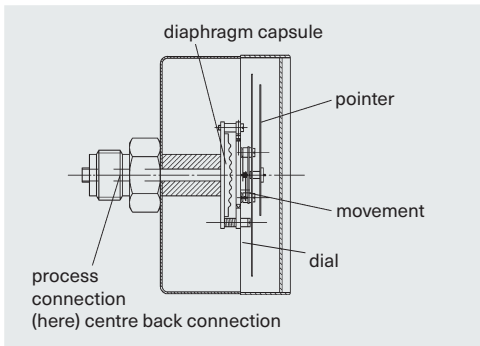

Pressure gauge with vertical diaphragm:

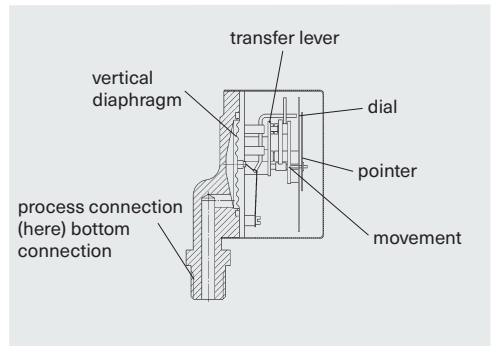

Pressure gauges for safety requirements according to DIN EN 837-1, S3 (former DIN 16006 part 1 and 2):

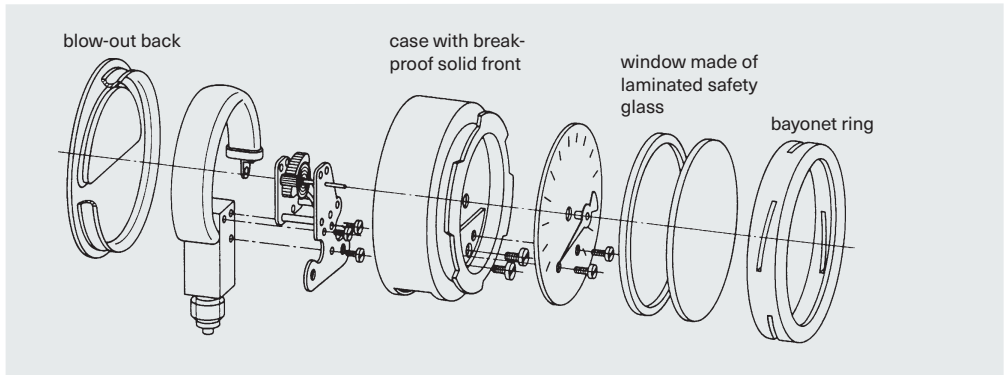

3.1.3 Construction Types Chemical Seals

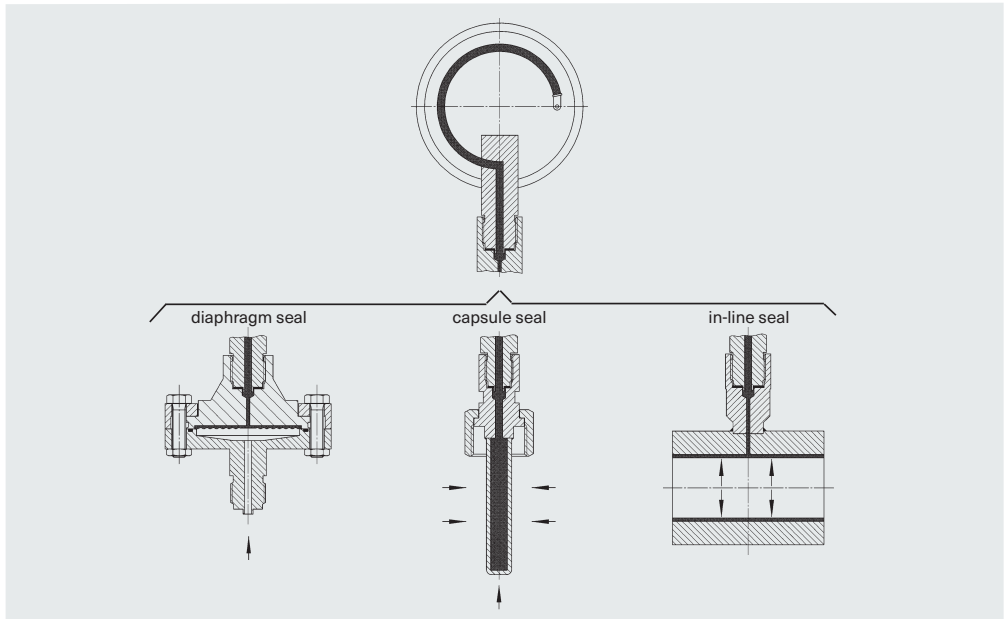

4. Selection Criteria

The user has to ensure that the proper pressure measuring instrument is selected regarding indication range and version (e.g. resistance of the materials against medium, atmosphere and temperature, overrange protection). The regulations applying to the particular application as well as DIN EN 837-2 have to be regarded.

4.1 Measuring Principles

The pressure measuring instruments, described in this operating instruction, contain measuring elements, which deform elastically when subjected to pressure. This motion is transferred to a movement. Due to their robustness and easy handling, these instruments (pressure gauges) are widely used in technical pressure measurement. The measuring elements are generally made of copper alloys or alloyed steels.

Bourdon tube pressure measuring instruments:

Bourdon tubes are circular bent tubes with an oval cross-section. The pressure to be measured acts on the inside of the tube, which results in the oval cross-section becoming almost circular. Due to the curvature of the tube, hoop stresses occur, which bend the Bourdon tube. The end of the Bourdon tube, which is not fixed, performs a motion, which is a measure for the pressure. For pressure ranges up to 40 bar, generally circular bent Bourdon tubes with a torsion angle of 270° are used. For higher pressure ranges, helical Bourdon tubes with several torsions are applied.

Bourdon tubes have a relatively low restoring force. When using additional accessories, such as drag indicators, limit switch contact assemblies or potentiometric transducers, therefore their influence on the indication has to be taken into account.

Bourdon tube resilient elements can only be protected against overload to a limited extent by supporting the measuring element at a specific pressure limit value.

Bourdon tube pressure gauges are applied for pressure ranges from 0.6 bar to 4000 bar, mostly with accuracy classes 0.6 to 2.5.

The influence of temperature changes on the indication mainly depends on the temperature coefficient of the modulus of elasticity of the Bourdon tube. Depending on the material used, the temperature-related error is between 0.3 % and 0.4 % per 10 K.

Diaphragm pressure gauges:

Diaphragms are circularly shaped corrugated membranes. The pressure to be measured acts on one side of the diaphragm. The deflection of the diaphragm is a measure for the pressure. Diaphragms have a relatively high restoring force. Therefore, the influence of additional accessories is lower compared to Bourdon tube pressure gauges. Due to the annular fixing arrangement of the diaphragm, they are less sensitive to vibrations. Diaphragms can be protected against high overload by supporting the measuring element. They can be protected against corrosive media by applying coatings or foils. Diaphragm pressure gauges are also favourable for highly viscous or crystallising media, since wide connection bores, open connection flanges or flushing orifices allow for cleaning options.

There are pressure gauges with horizontal diaphragm and pressure gauges with vertical diaphragm, i.e. the diaphragm is placed parallel to the dial. For pressure ranges < 0.6 bar, generally diaphragms with a diameter of 160 mm are used, whereas for higher pressure ranges diaphragms with a diameter of 100 mm are used. Due to the annular fixing arrangement of the diaphragm, the indication deviation caused by temperature changes is significantly higher compared to Bourdon tube pressure gauges. Diaphragm pressure gauges are applied for pressure ranges from 10 mbar to 25 bar with accuracy classes of 1.6 and 2.5, rarely also of 4.0.

Capsule gauges for low pressure:

A diaphragm capsule consists of two circularly shaped corrugated membranes or a membrane and a base plate, which are assembled pressure-tight at the edge. The measurement pressure is passed into the centre of one of the membranes and acts onto the inside of the diaphragm capsule. The lifting movement generated hereby is a measure for the pressure. Capsule gauges for low pressure are not suitable for liquid media.

They can be applied for pressure ranges from 2.5 mbar to 600 mbar with accuracy classes from 0.6 to 1.6.

The indication deviation caused by temperature changes can be between 0.3 % and 0.4 % per 10 K, depending on the material.

4.2 Pressure Ranges

The operating pressure should be within the middle third of the pressure range specified for the pressure gauge. The maximum pressure load should not exceed 75 % of the full scale value at steady load or 65 % of the full scale value at dynamic load (⇒ DIN EN 837-2).

4.3 Error Limits

The error limits for pressure measuring instruments are defined in DIN EN 837-1 (Bourdon tube pressure gauges) and DIN EN 837-3 (capsule gauges and diaphragm pressure gauges).

- Pressure measuring instruments with classes 0.1 to 0.6 and higher are preferably used in laboratories and workshops for precise measurements.
- Pressure measuring instruments with classes 1.0 and 1.6 are used for measurements on machines and in production facilities.
- Pressure measuring instruments with classes 2.5 and 4.0 are used for monitoring tasks without special accuracy requirements.

4.4 Operating Conditions



When selecting pressure measuring instruments, attention should be paid on the selection criteria and installation recommendations according to DIN EN 837-2 as well as the information provided in this manual (⇒ chapters 4.4.1, 4.4.2 and 6.). The application of pressure measuring instruments that are not suited for the actual operating conditions may cause considerable consequential damage.

4.4.1 Medium Properties, Pressure Profile



CAUTION! Material damage!

Rapid pressure changes or pressure strokes must not act abruptly on the measuring element. Pressure strokes must not exceed the pressure limits of the pressure measuring instruments.

If required, upstream overload protection devices (⇒ chapter 5 "Additional Accessory") shall be provided. Pressure changes of > 10 % of the full scale values per second impair the reading of the measured values. Moreover, this severely reduces the service life of the devices. In such cases, attenuators must be provided.

With snubber devices (restrictor screw or adjustable snubber), the inlet cross-section is significantly reduced. This results in a delay of the pressure change in the measuring element. The installation of a throttle section (reduction of the measuring line cross-section) is also possible. In both cases, the susceptibility to contamination is disadvantageous. Attenuators on the movement only decelerate the pointer motion. Liquid filled cases dampen the motion of the measuring element and reduce the wear of moving components.

Temperature:



If the medium temperature at the measuring point deviates from the permissible operating temperature of the pressure measuring instrument (⇒ chapter 8 "Intended Use" as well as DIN EN 837-1, -2, -3), a measuring line with sufficient length, a siphon or a chemical seal with capillary line must be connected upstream to the pressure gauge. The influence on the indication due to instrument temperatures deviating from +20 °C (+68 °F) has to be regarded.

Highly viscous, crystallising or solid-containing media:



For the pressure measurement of highly viscous, crystallising or solid-containing media, diaphragm pressure gauges or Bourdon tube pressure gauges with attached chemical seal (⇒ chapter 5 "Additional Accessory") are recommended.

Corrosive media:

If corrosive media can be kept away from the measuring element by separating agents, standard devices may be used.



Otherwise, the selection of the suitable material is mandatory, whereas the operator has to provide the manufacturer with any information concerning the materials that are compatible with the medium under the specific measuring conditions (⇒ DIN EN 837-2, 4.3). Due to the limited choice of materials for the elastic elements, diaphragm pressure gauges with a protective lining might be used, or chemical seals made of media resistant materials need to be connected upstream to a Bourdon tube pressure gauge.

Safety:

A higher risk exists, for example, with gases or liquids under high pressure. In case of leakage or bursting of pressure-retaining components, employees standing in front of the window of the device, must not be endangered by medium emerging to the front. Safety pressure gauges with a blow-out device at the rear side, e.g. a blow-out back, provide for protection (⇒ chapter 3.1.2). For hazardous media, such as

- oxygen
- acetylene
- combustible substances
- toxic substances

as well as for refrigerating units, compressors etc., the applicable regulations have to be regarded.



CAUTION!

In accordance with DIN EN 837-1, 9.7, liquid filled pressure gauges must be equipped with blow-out devices (version S1, S2 or S3 according to DIN EN 837-1).

4.4.2 Ambient Conditions

Vibrations:



If vibrations of the pressure gauge cannot be eliminated by appropriate installation, devices with movement attenuation or liquid filling should be used.

Ambient temperature:



The error limit given on the dial applies at a reference temperature of +20 °C (+68 °F). Deviating temperatures have an influence on the indication.

The extent of the influence depends on the measuring principle (⇒ chapter 4.1).

At outdoor installations, the prevailing ambient conditions must be taken into account by selection or protection, e.g. to prevent the pressure gauge from freezing over at temperatures below 0 °C (+32 °F). In liquid filled instruments, the viscosity of the fluid increases as the ambient temperature drops – causing a considerable indication delay.

The ambient temperature must also be taken into account regarding the maximum permissible operating temperature specified for the device.

Corrosive atmosphere:



In corrosive atmospheres, suitable casings and components made of resistant materials must be provided.

Special surface treatments serve as exterior protection.

5. Additional Accessory

Shut-off valves for pressure gauges:



It is recommended to install a shut-off device between measuring point and pressure gauge, which allows for an exchange of the pressure gauge and a zero point check while the system is running. Depending on the intended application, either cocks or valves are used.

Cocks have three positions:

- **Ventilation:**
The feed line is closed, the measuring element is open to the atmosphere. The zero point can be checked.
- **Operation:**
The feed line is open, the measuring element is pressurised.
- **Blow-out:**
The feed line is open, the medium is vented to the atmosphere. The measuring element is not in use.

For valves (e.g. according to DIN 16270 and DIN 16271), a vent screw is usually provided between valve seating and pressure gauge.



IMPORTANT! Ventilation to the atmosphere shall be arranged in a way that employees are not endangered by escaping medium.

Potential environmental damage is to be avoided. In certain applications (e.g. steam boilers), the shut-off valves require a test connection, so that the pressure measuring instrument can be checked without being disassembled.

Gauge holder bracket:



A suitable gauge holder is to be provided if the measuring line is not rigid enough for a vibration-free installation of the pressure measuring instrument.

Siphons:



Use measuring lines with an adequate length or siphons to protect the shut-off valves and the pressure gauges against heating due to hot media (e.g. steam).

Chemical seals:



For aggressive, hot, highly viscous or crystallising media, which must not enter the pressure element, chemical seals can be mounted to Bourdon tube pressure gauges to provide separation.

For transmission of the pressure to the pressure element, a neutral liquid is used, which is chosen to match the measuring range, temperature, viscosity and other influences by taking into account the compatibility of this liquid with the medium.

Chemical seals are available in various construction types (⇒ chapter 3.1.3 "Construction Types Chemical Seals"), whereas the diaphragm seal is the most commonly used model.

For in-line seals and flange type chemicals seals, the pressure gauge has to be mounted to the chemical seal by the manufacturer in accordance with the given installation position.

The connection between pressure gauge and chemical seal must not be separated.

Potential errors, influenced by mounting a chemical seal to a pressure gauge have to be regarded.

Overrange protection devices:



CAUTION! If the indication range has to be lower than the maximum operating pressure due to operational reasons, the pressure gauge can be protected against damage by fitting an overrange protection device.

In the event of a pressure stroke, the protection device closes instantly. If the pressure rises slowly, it closes gradually. The closing pressure to be set thus depends on the temporal pressure profile.

However, highly viscous and contaminated media might impair or disable the function of the protection device.

Capsule gauges and diaphragm pressure gauges can also be produced overrange protected (3-fold, 5-fold or 10-fold).

6. Measuring Arrangements

General remarks:

Proven arrangements for pressure measurement and suggestions for component parts are specified in VDE / VDI 3512 sheet 3. The following table gives an overview on the possible measuring arrangements:

State of the medium	liquid			gaseous		
	liquid	partly gas emitting	completely gas emitting	gaseous	partly condensed (moist)	completely condensed
Examples	condensate	boiling liquids	"liquid gases"	dry air	moist air flue gases	steam
a) Pressure gauge higher than measuring port	1 	2 	3 	4 	5 	6
b) Pressure gauge lower than measuring port	7 	8 		9 	10 	11

The arrangements 3, 4, 5, 7, 8 and 11 are to be preferred.

Pressure measuring port:



The pressure measuring port should be arranged at a position with unimpaired flow and consistent measuring conditions. It is recommended to choose a sufficiently large orifice for the pressure measurement and to close the measuring port with a shut-off device.

Measuring line:



The measuring line is the connection between measuring port and pressure gauge. The inner diameter of the line should be large enough to avoid plugging.

The measuring line should be installed with a steady incline (1:15 is recommended). If the medium is gaseous, a drain should be provided at the lowest point. If the medium is a highly viscous liquid, a vent should be provided at the highest point. If the gases or liquids contain solids, separators should be provided, which can be disconnected from the assembly by shut-off valves and emptied during operation. The measuring line should be arranged and fitted in a way that it can withstand stresses caused by expansion, vibration or the influence of heat.

Shut-off valves at the pressure gauge:

Shut-off valves at the pressure measuring instrument serve to check the zero point or to exchange the measuring instrument during operation (⇒ chapter 5 “Additional Accessory”).

Pressure measuring instrument:



The pressure measuring instrument needs to be mounted vibration-free and positioned for easy readability.

Parallax errors are to be avoided when reading the dial. It has to be ensured that any blow-out devices on the pressure gauge are protected against blocking (⇒ DIN EN 837-1, 9.7). The pressure gauge shall be arranged in a way that the temperature does not fall below or exceed the permissible operating temperature (⇒ chapter 4.4 “Operating Conditions” and chapter 8 “Intended Use”). Here, the influence of convection and thermal radiation has to be regarded. If the measuring element of a pressure gauge is filled with water or a water mixture, the instrument has to be protected against freeze. The pressure gauge is generally mounted with vertical dial. In all other cases, the position symbol on the dial according to DIN EN 837 applies.

A height difference between measuring port and pressure gauge causes a shift of the measuring start value if the medium in the measuring line does not have the same density as the ambient air. This shift of the measuring start Δp results from the density difference ($\rho_M - \rho_L$) and the height difference Δh : $10^{-5} \cdot (\rho_M - \rho_L) g \cdot \Delta h$

Δ	= shift of measuring start	[bar]
ρ_M	= density of the medium	[kg / m ³]
ρ_L	= density of the air (1.205 at 20 °C)	[kg / m ³]
Δh	= difference in height	[m]
g	= gravitational acceleration	[m / s ²]
	(medium gravitational acceleration 9.81 m / s ²)	

The indication is decreased by Δp if the pressure gauge is positioned higher than the pressure measuring port, and increased by Δp if it is positioned lower.

7. Installation

The mounting of pressure measuring instruments shall be carried out by qualified personnel only. For the measuring arrangements, please refer to chapter 6.

During installation or removal, the pressure gauge should never be held at the case, but at the wrench flat of the socket.



It must be ensured that the matching process connection has been selected (nominal width, if required, suitable sealing face etc.).

For instruments with thread connection, an installation with clamping sleeve or union nut is recommended, in order to position it for proper readability. Instruments with flange connections are fitted to the counter flange and secured with suitable screws. It must be ensured that the screws are firmly tightened.

The connections need to be leaktight. Therefore, sealings made of suitable medium-resistant material should be used for the connection. For the sealing of pressure measurement connections with cylindrical thread spigots, e.g. flat sealing rings according to DIN EN 837-1, profile packings or lens-type sealing rings for corresponding high pressure connections have to be applied at the sealing face. Conical threads (e.g. NPT threads) are sealed with additional sealing materials such as PTFE tape (⇒ DIN EN 837-2).

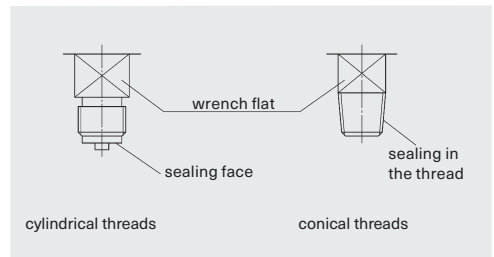

For pressure gauges with pressure ranges of ≤ 6 bar and pressure relief vent $\varnothing 13$ mm (0.51") at the top of the case, it is recommended to cut off the nipple on the filling plug in order to allow for internal pressure compensation by venting the pressure gauge.

If the pressure gauge is positioned lower than the pressure measuring port, the measuring line should be rinsed thoroughly before putting into operation to remove any foreign objects.

During pressure tests on pipes and vessels, no pressure higher than indicated on the dial by the maximum value mark ▼ must be applied to the pressure gauge and the specified application limit at steady load must not be exceeded (\Rightarrow chapter 8 "Intended Use").

For diaphragm pressure gauges, the clamping bolts for the upper and lower flange must not be loosened.

For instruments with attached chemical seal, the connections between pressure gauge and chemical seal and, if applicable, between chemical seal and capillary line must not be loosened.



IMPORTANT! Before dismantling the pressure gauge, the measuring unit has to be depressurised.

If necessary, the measuring line needs to be relieved. Medium residues in dismantled pressure gauges might endanger personnel, facilities and the environment. Adequate precautionary measures shall be taken.

8. Intended Use



CAUTION! Shut-off devices shall only be opened slowly in order to avoid sudden pressure strokes during commissioning.

Application range:

On many pressure measuring instruments, the application range for steady loads is indicated on the dial by the maximum value mark ▼ (\Rightarrow DIN EN 837-1, DIN EN 837-3).

At steady load, the Bourdon tube pressure gauges with nominal case size 100, 160 and 250 are loadable up to the full scale value. At dynamic load, only 0.9 times of this pressure is permissible as peak load, for the pressure ranges 0/2500 bar and 0/4000 bar max. $\frac{2}{3}$ of the full scale value. Bourdon tube pressure gauges are overrange protected up to 1.3 times the full scale value (0/2500 bar and 0/4000 bar instruments can only be loaded up to their full scale value!).

At steady load, the Bourdon tube pressure gauges with nominal case size 40, 50, 60, 63, 80 and 72x72 are loadable up to $\frac{3}{4}$ of the full scale value, at dynamic load up to max. $\frac{2}{3}$ of the full scale value and only temporarily to the full scale value.

At steady load, diaphragm pressure gauges with vertical diaphragm are loadable up to the full scale value, at dynamic load up to 0.9 times the full scale value.

Diaphragm pressure gauges with horizontal diaphragm are overrange protected up to 5 times the full scale value (custom-made instruments also higher), but never higher than 40 bar.

At steady load, capsule gauges for low pressure are loadable up to the full scale value, at dynamic load maximum up to 0.9 times the full scale value. Just as Bourdon tube pressure gauges, they are 1.3-times overrange protected (custom-made instruments also higher).

Zero point check:

In order to check the zero point of the pressure gauge during operation, the shut-off device, required for this purpose (⇒ chapter 5 “Additional Accessory”), will be shut and the pressure gauge will be relieved. The pointer must be positioned within the zero range indicated by \perp .

If the pointer remains outside of this range, this generally results from a lasting deformation of the measuring element, which needs to be submitted for a closer examination in order to avoid accidents due to measuring errors. In such a case, the device should be replaced and, if required, returned to the manufacturer for checking and repair.

Indication check:

If a check of the indication during operation is necessary, the pressure gauge is separated from the process via the required shut-off device with test connection (⇒ chapter 5 “Additional Accessory”) and pressurised with test pressure. The error limits according to DIN EN 837-1 and DIN EN 837-3 apply.

Temperature resistance:



The permissible operating temperatures of the pressure gauge must not be exceeded.

The temperature resistance or the permissible operating temperature generally is between max. -40 °C to $+60\text{ °C}$ (⇒ DIN EN 837-1 and DIN EN 837-3), whereas unfilled gauges with brazed Bourdon tube can withstand medium temperatures up to $+100\text{ °C}$ and stainless steel cases with shielded arc welding Bourdon tube can withstand medium temperatures up to $+200\text{ °C}$.

Special versions with corresponding dial inscription (t_A/t_R) might be suitable for higher temperatures.



Please note: these are only specifications concerning the temperature resistance of the materials as well as the soldered joints or weld seams. The specifications concerning indication errors due to deviations from the reference temperature are to be regarded! Detailed information can be found in our model overview 1000 for Bourdon tube pressure gauges.

Cleaning temperature:



During rinsing of the measuring line, the permissible operating temperature of the pressure gauge (see above) must not be exceeded.

If necessary, the device needs to be shut-off or removed. For pressure gauges with attached chemical seals, the maximum cleaning temperature t_R must not be exceeded.

9. Additional Accessories

The mounting and the electrical or pneumatic connection shall be carried out by qualified personnel only.

Instruments with electrical or pneumatic accessories are marked with a nameplate, which indicates how the connection has to be carried out.

It is necessary to regard the load limits. Exceeding the load limits might cause damage.

The national and international safety regulations (e.g. VDE 0100) have to be regarded during installation, commissioning and operation of the instruments.

9.1 Electrical Limit Switch Contact Assemblies

It must be ensured that the cable diameters match the nominal widths of the sealing inserts. Screw fittings must be tightened firmly. Only then compliance with certified degrees of protection can be ensured. In versions with angular plug, plug connector or terminal box, the centrally arranged fixing screws must be tightened hand-tight.

For the connection of pressure transmitters DMU, only shielded cable has to be used to ensure electromagnetic compatibility (EMC). The shield has to be connected to the case or the ground terminal of the angular plug.

Please regard that the CE mark according to the EMC directive for instruments with magnetic contact only applies when the frequency of operation does not exceed 5 switching cycles per minute.

If specified, suitable switch amplifiers or multifunctional relays have to be used (e.g. for instruments with inductive contact). The valid operating requirements have to be regarded.

9.2 Pneumatic Limit Switch Contact Assemblies

Pneumatic limit switch contact assemblies are used for opening or closing connected pneumatic circuits at the set limits.

They are directly built into the measuring instrument at factory. The built-in type is indicated on the measuring instruments. There, also switching function and pin assignment are depicted.

9.2.1 Operating Principle

The slot-type initiators used in the pneumatic contacts operate according to the air jet cutting system. The slot-type initiators are designed in a way that a jet nozzle and a collector nozzle are axially opposite each other on both sides of the air gap.

A constant supply air of 1.4 bar \pm 0.1 bar at the supply air connection is required as auxiliary energy. A capillary pressure regulator in the inlet in front of the jet nozzle reduces the pressure to approx. 0.1 bar. The outlet pressure at the collector nozzle is approx. 40 mbar. The air flow is interrupted when the control lug enters the slot-type initiator. Switching is activated without delay as soon as actual value pointer and limit setting pointer are congruent.

The downstreamed low-pressure switch (binary converter P/P) on the back converts the outlet pressure of 40 mbar into a standard signal of 1.4 bar (P/P) and has a snap-action switching behaviour.

The direction of action of the output signal at port 3 can be reversed by reconnecting the hose bridge on the binary converter from port 4 to port 5.

To prevent the nozzle system and the upstream capillary pressure regulator from being blocked, special requirements must be placed on the purity of the supply air. Impurities larger than 0.04 mm must be filtered out. If the temperature is below zero, the dew point of the working air must be kept 10 °C lower than the lowest possible temperature at the unit by drying the air.

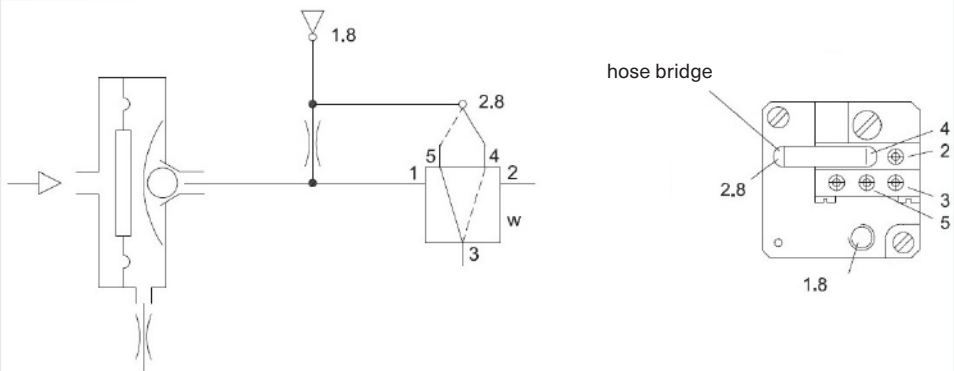

9.2.2 Adjusting the Limit Setting Pointers

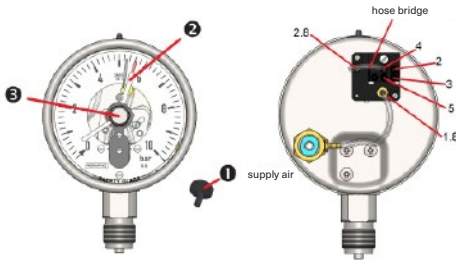

The set points are adjusted from the outside via an adjusting lock in the window.

With a separate or permanently fitted key (included with delivery), the limit setting pointers of the contact assemblies are set to the value at which the switching operation is to take place.

By pushing and simultaneously turning the adjusting key ① into the adjusting lock ③, the limit setting pointers ② can be set over the entire range of the dial.

For reasons of switching accuracy, switching reliability and service life of the measuring system, they should be set between 10 and 90 % of the respective measurement span.

10. Installation in Potentially Explosive Areas

10.1 General Information

Pressure gauges and pressure gauges with pneumatic limit switches are mechanical pressure measuring instruments that do not have any potential ignition sources during its intended operation. Versions made of stainless steel with laminated glass are suitable for the application in areas of category 2 and 3 according to ATEX directive 2014/34/EU.

For the application in category 1 (e.g. installation to zone 0), only pressure measuring instruments with integrated, type-approved flame arrester, our model Adapt FS, are suitable. This protection system avoids flame penetration in case of deflagrations of potentially explosive vapour-air and gas-air mixtures of explosion groups IIA, IIB and IIC in an upstreamed volume of max. 0.2 l. The flame arrester "Adapt FS" is certified with

Ⓔ II G IIC PTB 12 ATEX 4001 X

on condition that the operating pressure does not exceed 1.1 bar abs. and the operating temperature does not exceed 60 °C (140 °F).

To avoid heating of the measuring elements of Bourdon tube pressure gauges, dynamic load is not permissible with gaseous media!

If media can generate an electrostatic charge on a wetted PTFE coating, this PTFE coating has to be antistatic with a surface resistance of < 1000 kOhm.

10.2 Marking for the Explosion Hazardous Area

Pressure gauges without limit switch contact assembly are marked as follows for the application in explosion hazardous areas.

Example:

Bourdon tube pressure gauge model RCh100 – 3,
manufacturer ARMANO Messtechnik GmbH

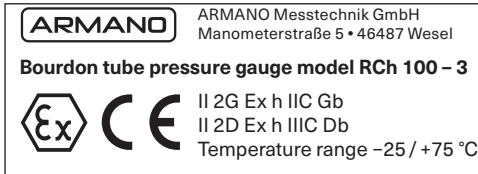

(content obligatory, free layout)

The maximum temperature of +75 °C (+167 °F) was determined as part of a "self-certification" with an additional safety of 10 K for the use in explosion hazardous areas, which require temperature class T6.

Please observe the temperature specifications on the nameplate to avoid hot surfaces due to increased ambient or medium temperatures.

Notwithstanding the above, for medium temperatures $T_M \geq 75$ °C, pressure gauge versions for combustible substances, which may come into contact with $T_M \geq 75$ °C, are available. They can be marked accordingly, the technical design remains unchanged.

If gas/air (dust/air) mixtures have a considerably higher ignition point than T_M , these would be such substances. (Written confirmation of the operator with description of the measuring point!)

Marking example for medium $T_M = 150$ °C (302 °F)

II 2G Ex h IIC Gb
II 2D Ex h IIIC Db
Temperature range –25 / +150 °C (–13 / +302 °F)
Only for measuring point ###!

In that example, this allows for use in potentially explosive atmospheres, which require temperature class T3 (maximum permissible surface temperature of the equipment < 200 °C (< 392 °F)).

(The prerequisite is that the pressure gauge is generally resistant to this temperature.)

Please contact the manufacturer in case of uncertainties.

11. Maintenance / Cleaning, Handling and Transport, Storage



CAUTION! Material damage and loss of warranty!

Any modifications or interventions in the device, made by the customer, might damage important parts or components. Such intervention leads to the loss of any warranty and manufacturer's responsibility!

→ Never modify the device or perform any repairs yourself.

Maintenance:

Pressure measuring instruments are generally maintenance-free.

Nevertheless, we recommend a regular check of the device for function and indication accuracy to ensure reliable operation and a long service life.

If there is any indication of damage, the device must be replaced immediately (⇒ chapter 2 "Safety Instructions" and chapter 12 "Dismounting and Disposal")!

Repairs may only be executed by the manufacturer.

Cleaning:

Before returning an instrument for repair, the wetted parts must be cleaned thoroughly, especially when using hazardous media. The repair order should include a description of the medium or a declaration of contamination.

Handling and transport:



Sensitive components!

The device contains sensitive components and has to be handled with due care.

To prevent any impairment of the metrological properties, it is essential to protect the devices from mechanical shocks or impacts during transport, installation and operation. Special attention must be paid to the following aspects:

- Do not throw or drop the device!
- Remove the devices carefully from their packaging.
- Avoid shocks caused by strong impacts on surfaces or with objects.
- Please use a suitable packaging for the transport (if possible, the original packaging) that adequately protects the devices from shocks.
- Provide relevant transportation instructions on the packaging.

Storage:

Please keep the pressure measuring instruments in their original packaging until mounting and store them protected against damage due to external influences.

If a measuring instrument was removed (e.g. for testing), it should be carefully placed back in its original packaging for further storage.

In general, the storage temperature should not fall below or exceed the temperature limitations of -40 °C and $+60\text{ °C}$ (\Rightarrow DIN EN 837-1 and DIN EN 837-3).

12. Dismounting and Disposal

Before dismounting:

The instrument must be unpressurised before dismounting! Please remove the instrument completely from its application area.

Disposal:



NO DOMESTIC WASTE!

The instrument comprises various materials. It shall not be disposed of together with domestic waste.

\rightarrow Bring the device to your local recycling plant

or

\rightarrow send the device back to your supplier or to the ARMANO Messtechnik GmbH.

13. CE Conformity

CE The CE marking of the instruments certifies the conformity with prevailing EU directives for placing products on the market within the European Union. The following directive applies:

2014/68/EU (PED)

Pressure measuring instruments by ARMANO Messtechnik GmbH with a pressure >0.5 bar are, defined as pressure equipment parts, subject to the Pressure Equipment Directive 2014/68/EU.

Our pressure measuring instruments according to DIN EN 837-1 "Bourdon tube pressure gauges" receive the CE-marking in accordance to the conformity assessment procedure if the full scale value is 200 bar and above.

Pressure gauges with flange connections $>DN 25$ or 1" or thread connection $> 1"$ receive the CE-marking if the full scale value is 0.5 bar and above.

The CE-marking is placed on the outside of the case:

Pressure gauges with nominal case sizes 40, 50:



Production Location
Grünhain-Beierfeld



Production Location
Wesel-Ginderich

Measuring instruments with a full scale value >0.5 bar and <200 bar, which are subject to article 4 paragraph 3, do not receive a CE-marking.

Pressure gauges with nominal case sizes 63, 80, 100, 160, 250, 4½", 96x96, 144x144:



Measuring instruments with a full scale value >0.5 bar and <200 bar, which are subject to article 4 paragraph 3, do not receive a CE-marking.

The standard unit for the maximum permissible pressure (PS) is [bar].

Conversion factors for other technical pressure units:

1 bar = 0.100 MPa (100 kPa, 100000 Pa)
1.020 kg/cm² (kp/cm²)
14.504 psi
33.455 ft. Ws
401.463 in. Ws
29.530 in. Hg
750.064 mmHg (Torr)
10.197 mWs (10000 mmWs)

14. Declarations of Conformity

EU-Konformitätserklärung

EU Declaration of Conformity

Für die nachfolgend bezeichneten Erzeugnisse

We hereby declare for the following named goods

ROHRFEDER-MANOMETER
Typ R...

BOURDON TUBE PRESSURE GAUGES
Model R...

PLATTENFEDER-MANOMETER
Typ (A)P...

DIAPHRAGM PRESSURE GAUGES
Model (A)P...

DIFFERENZDRUCK- ODER DOPPEL-MANOMETER
Typ D(i)R..., DiK...

DIFFERENTIAL OR DUPLEX PRESSURE GAUGES
Model D(i)R..., DiK...

KAPSELFEDER-MANOMETER
Typ K...

CAPSULE PRESSURE GAUGES
Model K...

wird hiermit bestätigt, dass sie den folgenden Normen entsprechen: *that they comply with the following standards:*

DIN EN 837-1:1997-02
DIN EN 837-3:2019-08

Sie werden gemäß den Bestimmungen folgender Richtlinie gefertigt:

They are manufactured according to the requirements of directive:

RICHTLINIE 2014/68/EU DES EUROPÄISCHEN PARLAMENTS UND DES RATES VOM 15. Mai 2014 zur Angleichung der Rechtsvorschriften der Mitgliedstaaten über Druckgeräte – kurz: **Druckgeräterichtlinie**

DIRECTIVE 2014/68/EU OF THE EUROPEAN PARLIAMENT AND THE COUNCIL from May 15, 2014 on the approximation of the laws of the Member States relating to pressure equipment – short: **Pressure Equipment Directive**

Mit Skalendendwerten ab 200 bar oder Flanschanschlüssen ab DN 25 und Skalendendwerten ab 0,5 bar fallen sie ihrer Art nach unter „Druckhaltende Ausrüstungsteile“ und werden folgendem Konformitätsbewertungsverfahren unterzogen:

With full scale values from 200 bar or flange connections from DN 25 and full scale values from 0.5 bar, they are, as pressure equipment parts, subjected to the following conformity assessment procedure:

Modul A2 „Interne Fertigungskontrolle mit Überwachung der Abnahme“

Module A2 "Internal Production Control with Surveillance of Final Assessment"

Name & Anschrift der verantwortlichen Stelle, die unser Qualitätssicherungssystem überwacht:

Name & address of the responsible body controlling our quality assurance system:

TÜV NORD Systems GmbH & Co. KG
Meidericher Straße 16
D-47058 Duisburg

TÜV NORD Systems GmbH & Co. KG
Meidericher Straße 16
D-47058 Duisburg

Kennnummer: **0045**

Identification number: 0045

Die CE-Kennzeichnung erfolgt mittels Aufkleber auf dem Gehäuse.

The CE-marking is made via sticker on the case.

Diese Erklärung wird verantwortlich für den Hersteller:
This declaration is issued under the sole responsibility of the manufacturer:

ARMANO Messtechnik GmbH
abgegeben durch / by
Grünhain-Beierfeld, 2024-01-09

Bernd Vetter
Geschäftsführender Gesellschafter / Managing Director

ARMANO Messtechnik GmbH
Standort Beierfeld
Am Gewerbestraße 9
08344 Grünhain-Beierfeld
Tel.: +49 3774 58 – 0
Fax: +49 3774 58 – 545
mail@armano-beierfeld.com

Standort Wesel
Manometerstraße 5
46487 Wesel-Ginderich
Tel.: +49 2803 9130 – 0
Fax: +49 2803 1035
mail@armano-wesel.com

100 EU poDgudemlvw?H-Konformitätserklärung DGR_LRM PM DI K_Ausg_01/24

EU-Konformitätserklärung

EU Declaration of Conformity

Für die nachfolgend bezeichneten Erzeugnisse

We hereby declare for the following named goods

MANOMETER

Typen RCh..., RSCh..., RChg..., RQ..., RF..., Pm..., PCh...,
PSC..., PsP..., D(I)RCh..., DIRZCh..., KPB..., KPCh...

PRESSURE GAUGE

Models RCh..., RSCh..., RChg..., RQ..., RF..., Pm..., PCh...,
PSC..., PsP..., D(I)RCh..., DIRZCh..., KPB..., KPCh...

THERMOMETER

Typen TBl..., TSChg..., TGeIChg..., TFChg..., TA..., TSCh...,
TGeICh..., TF..., TRCh...

THERMOMETER

Models TBl..., TSChg..., TGeIChg..., TFChg..., TA..., TSCh...,
TGeICh..., TF..., TRCh...

ohne Grenzsignalgebern

without Limit Switch Contact Assemblies

wird hiermit erklärt, dass sie den wesentlichen Schutzanforderungen entsprechen, die in der nachfolgend bezeichneten Richtlinie festgelegt sind:

that they meet the essential protective requirements, which have been fixed in the following directives:

RICHTLINIE 2014/34/EU DES EUROPÄISCHEN PARLAMENTS UND DES RATES vom 26. Februar 2014 für Geräte und Schutzsysteme zur bestimmungsgemäßen Verwendung in explosionsgefährdeten Bereichen – kurz:

DIRECTIVE 2014/34/EU OF THE EUROPEAN PARLIAMENT AND THE COUNCIL from February 26, 2014 relating to equipment and protective systems intended for use in potentially explosive atmospheres – short:

ATEX-Richtlinie

ATEX Directive

Zur Beurteilung der Erzeugnisse hinsichtlich der Richtlinie wurden folgende Normen herangezogen:

The following standards have been used to assess the goods regarding the directive:

DIN EN 80079-36:2016-12
DIN EN 1127-1:2019-10
DIN EN 80079-37:2016-12

Kennzeichnung:

Marking:

  II 2G Ex h IIC Gb
II 2D Ex h IIIC Db

  II 2G Ex h IIC Gb
II 2D Ex h IIIC Db

Temperaturbereich: -25 °C* / +75 °C

Temperature range: -25 °C* / +75 °C

* optional bis -60 °C, je nach Gerätetyp und Anforderung

* optionally down to -60 °C, depending on model and requirement

Diese Erklärung wird verantwortlich für den Hersteller:
This declaration is issued under the sole responsibility of the manufacturer:

ARMANO Messtechnik GmbH

abgegeben durch / by
Grünhain-Beierfeld, 2023-06-12



Bernd Vetter
Geschäftsführender Gesellschafter / Managing Director

ARMANO

ARMANO Messtechnik GmbH

Standort Beierfeld

Am Gewerbehaupt 9
08344 Grünhain-Beierfeld
Tel.: +49 3774 58 – 0
Fax: +49 3774 58 – 545
mail@armano-beierfeld.com

Standort Wesel

Manometerstraße 5
46487 Wesel-Ginderich
Tel.: +49 2803 9130 – 0
Fax: +49 2803 1035
mail@armano-wesel.com

www.armano-messtechnik.de

EU-Konformitätserklärung

EU Declaration of Conformity

Für die nachfolgend bezeichneten Erzeugnisse

ROHRFEDER-MANOMETER
Typ R...

DIFFERENZDRUCK- ODER DOPPEL-MANOMETER
Typ D(i)R...

in Kombination mit

DRUCKMITTLER
Typ MDM 7190 gemäß Datenblatt 7190
Typ MDM 72.. gemäß Datenblatt 7210, 7211, 7280
Typ MDM 73.. gemäß Datenblatt 7300, 7301, 7302, 7303, 7390
Typ MDM 74.. gemäß Datenblatt 7400
Typ MDM 75.. gemäß Datenblatt 7500, 7501, 7502, 7505, 7590
Typ MDM 76.. gemäß Datenblatt 7600, 7630, 7680
Typ MDM 79.. gemäß Datenblatt 7935, 7952

wird hiermit bestätigt, dass sie den jeweils gültigen Normen entsprechen und gemäß den Bestimmungen folgender Richtlinie gefertigt werden:

2014/68/EU (Druckgeräte-Richtlinie)

Druckmittel mit Anschlussnennweiten > DN 25/1" bzw. Gewindeanschlüssen >1" werden in Verbindung mit einem angebauten Druckmessgerät mit Skalendendwerten >0,5 bar folgendem Konformitätsbewertungsverfahren unterzogen:

Modul A2
„Interne Fertigungskontrolle mit Überwachung der Abnahme“

Benannte Stelle:
TÜV NORD Systems GmbH & Co. KG
Meidericher Straße 16
D-47058 Duisburg

Kennnummer: 0045

Die CE-Kennzeichnung erfolgt mittels Aufkleber auf dem Gehäuse.

We hereby declare for the following named goods

BOURDON TUBE PRESSURE GAUGES
Type R...

DIFFERENTIAL OR DUPLEX PRESSURE GAUGES
Type D(i)R...

in combination with

CHEMICAL SEALS
Model MDM 7190 acc. to data sheet 7190
Model MDM 72.. acc. to data sheet 7210, 7211, 7280
Model MDM 73.. acc. to data sheet 7300, 7301, 7302, 7303, 7390
Model MDM 74.. acc. to data sheet 7400
Model MDM 75.. acc. to data sheet 7500, 7501, 7502, 7505, 7590
Model MDM 76.. acc. to data sheet 7600, 7630, 7680
Model MDM 79.. acc. to data sheet 7935, 7952

that they comply with the valid standards and are manufactured according to the requirements of directive:

2014/68/EU (Pressure Equipment Directive)

Chemical seals attached to a pressure measuring instrument with full scale values >0.5 bar, with process connections >DN 25/1" or thread connections >1" are subjected to the following conformity assessment procedure:

Module A2
"Internal Production Control with Surveillance of Final Assessment"

Notified body:
TÜV NORD Systems GmbH & Co. KG
Meidericher Straße 16
D-47058 Duisburg

Identification number: 0045

The CE-marking is made via sticker on the case.

134 EU-Konformitätserklärung RM_Di_mf_DM Ausg. 01/24

Diese Erklärung wird verantwortlich für den Hersteller:
This declaration is issued under the sole responsibility of the manufacturer:

ARMANO Messtechnik GmbH

abgegeben durch / by
Grünhain-Beierfeld, 2024-01-09

Bernd Vetter
Geschäftsführender Gesellschafter / Managing Director

ARMANO

ARMANO Messtechnik GmbH
Standort Beierfeld
Am Gewerbepark 9
08344 Grünhain-Beierfeld
Tel.: +49 3774 58 - 0
Fax: +49 3774 58 - 545
mail@armano-beierfeld.com

Standort Wesel
Manometerstraße 5
46487 Wesel-Ginderich
Tel.: +49 2803 9130 - 0
Fax: +49 2803 1035
mail@armano-wesel.com

www.armano-messtechnik.de

EU-Konformitätserklärung

EU Declaration of Conformity

Für die nachfolgend bezeichneten Erzeugnisse

We hereby declare for the following named goods

MANOMETER
Typen RCh..., RSCh...

PRESSURE GAUGES
Models RCh..., RSCh...

mit pneumatischen Grenzsinalgebern

with Pneumatic Limit Switch Contact Assemblies

wird hiermit erklärt, dass sie den wesentlichen Schutzanforderungen entsprechen, die in der nachfolgend bezeichneten Richtlinie festgelegt sind:

that they meet the essential protective requirements, which have been fixed in the following directive:

RICHTLINIE 2014/34/EU DES EUROPÄISCHEN PARLAMENTS UND DES RATES vom 26. Februar 2014 für Geräte und Schutzsysteme zur bestimmungsgemäßen Verwendung in explosionsgefährdeten Bereichen – kurz:

DIRECTIVE 2014/34/EU OF THE EUROPEAN PARLIAMENT AND THE COUNCIL from February 26, 2014 relating to equipment and protective systems intended for use in potentially explosive atmospheres – short:

ATEX-Richtlinie

ATEX Directive

Zur Beurteilung der Erzeugnisse hinsichtlich der Richtlinie wurden folgende Normen herangezogen:

The following standards have been used to assess the goods regarding the directive:

DIN EN 80079-36:2016-12
DIN EN 1127-1:2019-10
DIN EN 80079-37:2016-12

Kennzeichnung:

Marking:

  II 2G Ex h IIC Gb
II 2D Ex h IIIC Db

  II 2G Ex h IIC Gb
II 2D Ex h IIIC Db

Temperaturbereich: -25 °C* / +75 °C

Temperature range: -25 °C / +75 °C*

* optional bis -60 °C, je nach Gerätetyp und Anforderung

** optionally up to -60 °C, depending on model and requirement*

Diese Erklärung wird verantwortlich für den Hersteller:
This declaration is issued under the sole responsibility of the manufacturer:

ARMANO Messtechnik GmbH
abgegeben durch / by
Grünhain-Beierfeld, 2022-10-07



Bernd Vetter
Geschäftsführender Gesellschafter / Managing Director

ARMANO

ARMANO Messtechnik GmbH
Standort Beierfeld
Am Gewerbehof 9
08344 Grünhain-Beierfeld
Tel.: +49 3774 58 – 0
Fax: +49 3774 58 – 545
mail@armano-beierfeld.com

Standort Wesel
Manometerstraße 5
46487 Wesel-Ginderich
Tel.: +49 2803 9130 – 0
Fax: +49 2803 1035
mail@armano-wesel.com

EU-Konformitätserklärung

EU Declaration of Conformity

Für die nachfolgend bezeichneten Erzeugnisse

We hereby declare for the following named goods

PLATTENFEDER-MANOMETER
Typen PCh..., PSCh...
mit antistatischer PTFE-Folie

DIAPHRAGM PRESSURE GAUGE
Models PCh..., PSCh...
with antistatic PTFE foil

ROHRFEDER-MANOMETER
Typen RCh..., RSCh..., RChg...

BOURDON TUBE PRESSURE GAUGE
Models RCh..., RSCh..., RChg...

in Kombination mit

combined with

DRUCKMITTLER
Typ MDM 72.. gemäß Datenblatt 7210, 7211
Typ MDM 73.. gemäß Datenblatt 7300, 7301, 7302, 7303
Typ MDM 75.. gemäß Datenblatt 7500, 7505
mit antistatischer PTFE-Folie

CHEMICAL SEALS
Model MDM 72.. acc. to data sheets 7210, 7211
Model MDM 73.. acc. to data sheets 7300, 7301, 7302, 7303
Model MDM 75.. acc. to data sheets 7500, 7505
with antistatic PTFE foil

ohne Grenzsinalgeberrn

without Limit Switch Contact Assemblies

wird hiermit erklärt, dass sie den wesentlichen Schutzanforderungen entsprechen, die in der nachfolgend bezeichneten Richtlinie festgelegt sind:

that they meet the essential protective requirements, which have been fixed in the following directives:

RICHTLINIE 2014/34/EU DES EUROPÄISCHEN PARLAMENTS UND DES RATES vom 26. Februar 2014
für Geräte und Schutzsysteme zur bestimmungsgemäßen Verwendung in explosionsgefährdeten Bereichen – kurz:

DIRECTIVE 2014/34/EU OF THE EUROPEAN PARLIAMENT AND THE COUNCIL from February 26, 2014
relating to equipment and protective systems intended for use in potentially explosive atmospheres – short:

ATEX-Richtlinie

ATEX Directive

Zur Beurteilung der Erzeugnisse hinsichtlich der Richtlinie wurden folgende Normen herangezogen:

The following standards have been used to assess the goods regarding the directive:

DIN EN 80079-36:2016-12
DIN EN 1127-1:2019-10
DIN EN 80079-37:2016-12

Kennzeichnung:

Marking:



Temperaturbereich: -25 °C* / +75 °C

Temperature range: -25 °C* / +75 °C

* optional bis -60 °C, je nach Gerätetyp und Anforderung

* optionally down to -60 °C, depending on model and requirement

Diese Erklärung wird verantwortlich für den Hersteller:

This declaration is issued under the sole responsibility of the manufacturer:

ARMANO Messtechnik GmbH

abgegeben durch / by
Grünhain-Beierfeld, 2024-04-25

Bernd Vetter
Geschäftsführender Gesellschafter / Managing Director

ARMANO

ARMANO Messtechnik GmbH

Standort Beierfeld
Am Gewerbestraße 9
08344 Grünhain-Beierfeld
Tel.: +49 3774 58 – 0
Fax: +49 3774 58 – 545
mail@armano-beierfeld.com

Standort Wesel
Manometerstraße 5
46487 Wesel-Ginderich
Tel.: +49 2803 9130 – 0
Fax: +49 2803 1035
mail@armano-wesel.com

www.armano-messtechnik.de



ARMANO Messtechnik GmbH

Location Beierfeld

Am Gewerbepark 9
08344 Grünhain-Beierfeld
Tel.: +49 3774 58 – 0
Fax: +49 3774 58 – 545
mail@armano-beierfeld.com

Location Wesel

Manometerstraße 5
46487 Wesel-Ginderich
Tel.: +49 2803 9130 – 0
Fax: +49 2803 1035
mail@armano-wesel.com