

ARMANO

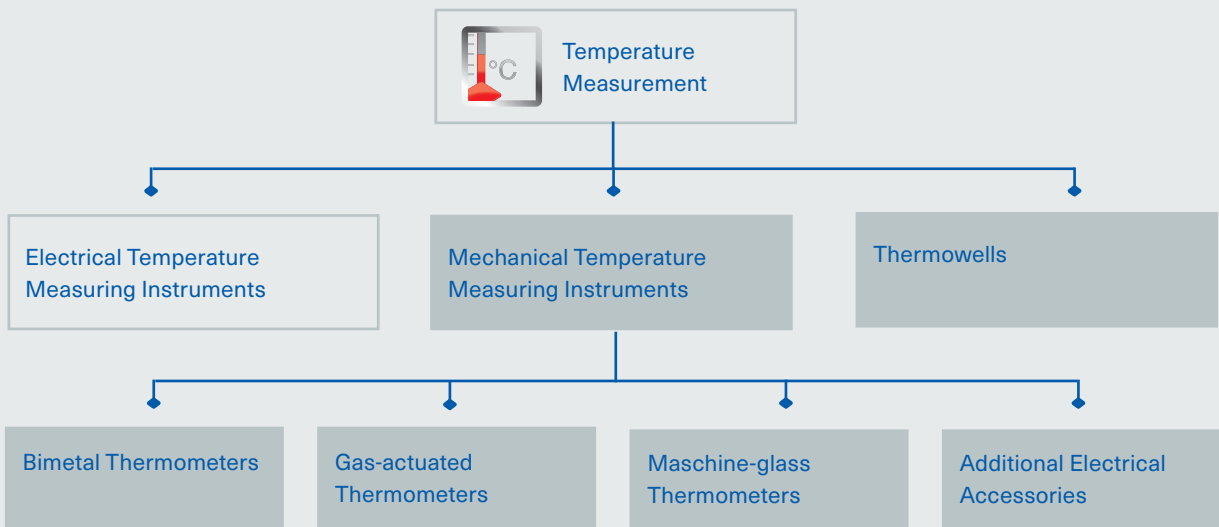

Mechanical Temperature Measurement



Quality Made in Germany

Mechanical Temperature Measurement

The ARMANO Messtechnik GmbH represents tradition and innovation in the production and distribution of precision pressure and temperature measuring instruments, which have an excellent reputation worldwide – for more than 100 years.

We are continually developing customer-specific solutions for a variety of applications requiring pressure and temperature measuring technology. Their use is manifold and there are always new applications.

Our production range of this segment mechanical temperature measurement includes bimetal thermometers, gas-actuated thermometers as well as thermometer thermowells and other accessories.

In this brochure, you will find our range of temperature measuring instruments for the mechanical temperature measuring technology, including additional electrical accessories.

Your instrument is not listed here? Jointly, we will find a suitable solution for your application.

Do not hesitate to contact us!

Certificates and Approvals	4
General Information Concerning the Selection	5
Technical Data	6
Bimetal Thermometers	8
Gas-actuated Thermometers	10
Temperature Sensors (Stems)	14
Thermowells	16
Machine-glass Thermometers	20
Additional Electrical Accessories	21
Accessories	22
General Installation Information	23

Our Products at a Glance



Mechanical Pressure Measurement



Electronic Pressure Measurement



Chemical Seal Mounting



Calibration Technology



Mechanical Temperature Measurement



Electrical Temperature Measurement



Thermowells & Accessories

Certificates and Approvals

Standards

Our company is certified according to the highest quality standards and our product portfolio meets the highest quality demands. We do not only manufacture according to product-specific instrument standards, we also offer versions with special approvals for application areas with specific requirements. The ARMANO Messtechnik GmbH is certified according to DIN EN ISO 9001.



SIL 2
SIL 3



General Information Concerning the Selection

To select a suitable thermometer for a particular measuring task, the operating conditions prevailing on site have to be regarded. Important information on the optimal design of your thermometers can be found in our technical information sheet T08-000-031. We are pleased to help you selecting the suitable thermometer for your particular case of application.

Analysis of the Operating Conditions

- ◆ Mechanical operating conditions, such as maximum process pressure, flow rate, occurring vibrations and shocks
- ◆ Thermal operating conditions: process and ambient temperature
- ◆ Data concerning the medium, important for the evaluation of the chemical resistance of the stem material
- ◆ Special process conditions or requirements, such as complicated installation conditions for the stem, no direct readability since the measuring point is hidden from view or difficult to access, the necessity to replace thermometers during ongoing processes

Examples:

- The medium pressure is > 25 bar.
- The application of a thermowell is required.
- Vibrations or shocks do occur.
- Thermometers with liquid case filling are favourable.
- Strong ambient temperature variations do occur.
- Bimetal thermometers work well.

Disregarding the operating conditions may result in additional errors, malfunctions up to instrument failures!

Selection Criteria

		Bimetal	Gas-actuated
Temperature ranges		from -50 °C up to +600 °C	from -100 °C up to +600 °C
Accuracy class		class 1	class 1
Stem length		up to 800 mm	up to 2.50 m
Version with	capillary line possible	no	yes, up to 15 m (> 15 m upon request)
	limit switch contact assembly	no	yes
Influence of the ambient temperature		no influence	yes
Compensation of the ambient temperature influence	on the case	not required	partial compensation
	on the capillary line	-	no
Vibration resistance	without case filling	no	limited
	with case filling	limited	good
Dependency on the position		no	no
Environmental compatibility		good	good

Technical Data

Dial

Dial inscriptions, temperature ranges, scale divisions and figures on the scale are designed according to DIN EN 13190. The standard dial is white with a black inscription.

The scale angle is $270 \pm 20^\circ$. All pointer thermometers are provided with a clearly identifiable instrument number on the dial.

Temperature Range / Measuring Range / Error Limits According to DIN EN 13190

» The **temperature range** indicates the scale range of a thermometer.

» The **measuring range** is equivalent to the range in which the error limits do apply. The measuring range is marked by arrows at the outer circumference of the scale.

» The **error limit** of our thermometers corresponds to class 1 according to DIN EN 13190 and is indicated by absolute values (see tables below), e.g. $\pm 1^\circ\text{C}$.

The information on the accuracy class is given on the bottom right of the dial.

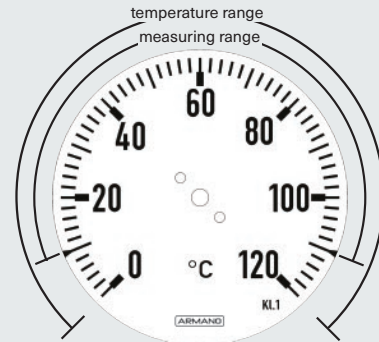

Temperature range: 0 °C to +120 °C
Measuring range: +10 °C to +110 °C
Error limit (permissible error) according to DIN EN 13190: $\pm 2^\circ\text{C}$

Temperature range	Measuring range	Smallest subdivision °C	Error limits acc. to cl. 1 +/- °C	Available for measuring systems
0 – 60 °C	10 – 50 °C	1	1	bimetal
0 – 80 °C	10 – 70 °C	1	1	bimetal and gas-actuated
0 – 100 °C	10 – 90 °C	1	1	
0 – 120 °C	10 – 110 °C	2	2	
0 – 160 °C	20 – 140 °C	2	2	
0 – 200 °C	20 – 180 °C	2	2	
0 – 250 °C	30 – 220 °C	5	2.5	
0 – 300 °C	30 – 270 °C	5	5	
0 – 400 °C	50 – 350 °C	10	5	
0 – 500 °C	50 – 450 °C	10	5	
0 – 600 °C	100 – 500 °C	10	10	
-100 / +100 °C	-80 / +80 °C	2	2	gas-actuated
-50 / +50 °C	-40 / +40 °C	1	1	bimetal and gas-actuated
-40 / +40 °C	-30 / +30 °C	1	1	
-40 / +60 °C	-30 / +50 °C	1	1	
-30 / +50 °C	-20 / +40 °C	1	1	
-30 / +70 °C	-20 / +60 °C	1	1	
-20 / +40 °C	-10 / +30 °C	1	1	bimetal
-20 / +60 °C	-10 / +50 °C	1	1	bimetal and gas-actuated
-20 / +80 °C	-10 / +70 °C	1	1	
50 – 300 °C	80 – 270 °C	5	2.5	gas-actuated
50 – 400 °C	100 – 350 °C	5	5	
100 – 500 °C	150 – 450 °C	10	5	

Temperature range	Measuring range	Smallest subdivision °F	Error limits acc. to cl. 1 +/- °F	Available for measuring systems	
0 – 150 °F	20 – 130 °F	2	1.8	bimetal and gas-actuated	
0 – 200 °F	20 – 180 °F	5	3.6		
0 – 250 °F	20 – 230 °F	5	3.6		
0 – 300 °F	40 – 260 °F	5	3.6		
-50 / +130 °F	-30 / +110 °F	2	1.8		
-40 / +160 °F	-20 / +140 °F	5	3.6		
-30 / +120 °F	-10 / +100 °F	2	1.8		
-10 / +100 °F	10 – 80 °F	2	1.8		bimetal
20 – 240 °F	40 – 220 °F	5	3.6		bimetal and gas-actuated
30 – 140 °F	50 – 120 °F	2	1.8		bimetal
40 – 400 °F	80 – 360 °F	5	3.6	bimetal and gas-actuated	
50 – 300 °F	70 – 280 °F	5	3.6		
50 – 500 °F	100 – 450 °F	5	4.5	bimetal	
80 – 800 °F	170 – 710 °F	10	9.0		
100 – 800 °F	150 – 750 °F	10	9.0	gas-actuated	
100 – 1000 °F	190 – 910 °F	10	9.0		
150 – 700 °F	200 – 650 °F	10	9.0	bimetal and gas-actuated	

Technical Data

Case Filling

Pointer thermometers are filled with a damping fluid to protect them from vibrations and impacts. The damping prevents the sensitive mechanically moving parts from excessive wear and improves the readability.

Together with the case, also the stems of the bimetal thermometers are filled in order to protect the bimetal coil.

For this type, the temperature ranges are thus limited.

Thermometer model	Damping fluid	Temperature ranges
Gas-actuated thermometer	silicone oil	all temperature ranges
Bimetal thermometer	glycerin (standard)	start of scale: $\geq -20\text{ °C}$ and end of scale: $\leq +100\text{ °C}$
	silicone oil (use only outside of the application limits of glycerin)	start of scale: $\geq -40\text{ °C to } < -20\text{ °C}$ and / or end of scale: $> +100\text{ °C to } \leq +250\text{ °C}$

Temperature Resistance

- ◆ Storage temperature: $-40\text{ °C to } +70\text{ °C}$
- with glycerin filling $-20\text{ °C to } +70\text{ °C}$
- ◆ Ambient temperature:
- unfilled (dry) version $-40\text{ °C to } +60\text{ °C}$
- special version $-60\text{ °C to } +60\text{ °C}$
- filled version $-20\text{ °C to } +60\text{ °C}$
- special version $-60\text{ °C to } +60\text{ °C}$
- ◆ Reference temperature: $+23\text{ °C } \pm 2\text{ °C}$
- ◆ Medium temperature (temperature at the stem) needs to be within the measuring range limits of the respective thermometer. For some models, higher- or lower-temperature resistant versions are available upon request.

Please regard possible limitations of storage or ambient temperature in the respective data sheets. Please do not hesitate to contact us if you require instruments with a higher or lower storage / ambient temperature.

Bimetal Thermometers

Bimetal thermometers according to DIN EN 13190 are pointer thermometers, which are actuated by spiral or helical bimetallic strips. The temperature-dependent rotational movement of the bimetal is directly transferred to the pointer via the pointer shaft.

Construction

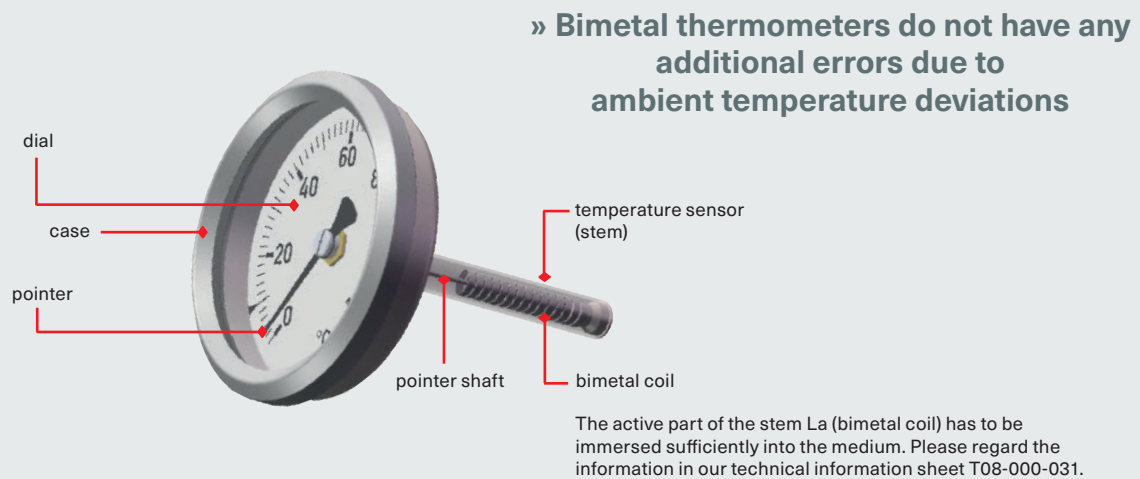

Bimetal Thermometers – Standard Range



Rigid Mount to the Stem

TBiSch

Case / ring	bayonet ring case stainless steel
Case filling	without
Nominal size	63, 100, 160 mm
Stem	stainless steel 316Ti (1.4571)
Stem types	B1, B3, B4, B4.1, B5 or B6
Data sheet	8101



Rigid Mount to the Stem

TBiSchg / TBiSchgG

Case / ring	crimped-on ring case stainless steel
Case filling	without / with
Nominal size	63, 80, 100, 125, 160 mm
Stem	stainless steel 316Ti (1.4571)
Stem types	B1, B3, B4, B4.1, B5 or B6
Data sheet	8102



**Every Angle
Turnable and Adjustable**

TBiGelCh

Case / ring	bayonet ring case stainless steel
Case filling	without
Nominal size	63, 100, 160 mm
Stem	stainless steel 316Ti (1.4571)
Stem types	B1, B3, B4, B4.1, B5 or B6
Data sheet	8111



**Every Angle
Turnable and Adjustable**

TBiGelChg / TBiGelChgG

Case / ring	crimped-on ring case stainless steel
Case filling	without / with
Nominal size	63, 80, 100, 125, 160 mm
Stem	stainless steel 316Ti (1.4571)
Stem types	B1, B3, B4, B4.1, B5 or B6
Data sheet	8112

Gas-actuated Thermometers

Gas-actuated thermometers according to DIN EN 13190 use the temperature-dependent pressure of a spatially enclosed quantity of gas as measure for the temperature. The measuring system consists of vessel (active part of the stem), capillary line and measuring element. It is filled with an inert gas, usually nitrogen. The indication is realised via movement and pointer.

Construction and Metrological Information

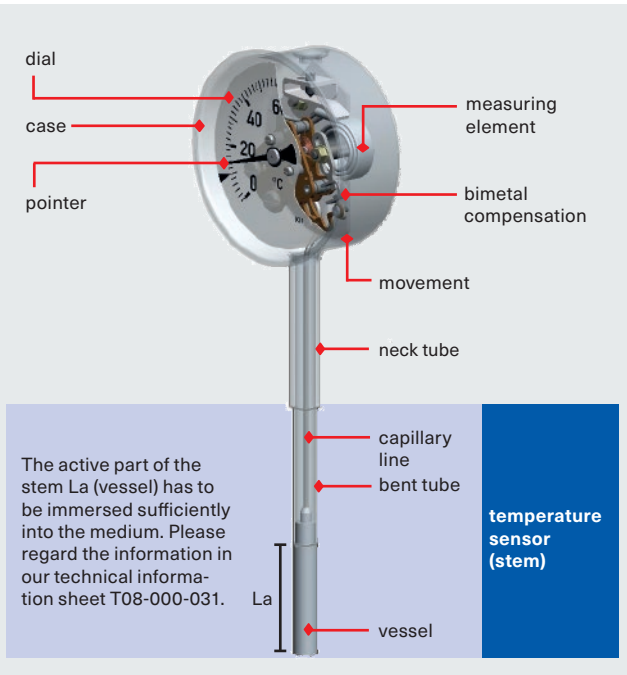

- ◆ If the temperature at the capillary line and / or case deviates from the reference temperature ($23\text{ °C} \pm 2\text{ °C}$), environmental additional errors occur due to the measuring principle of the gas-actuated thermometers.
- ◆ The ambient temperature influence on the measuring result can be kept small if the active gas volume (vessel content) is very large compared to the inactive gas volume (capillary line and measuring element). Upon request, we manufacture thermometer stems with a vessel volume adjusted to the specific case of application.
- ◆ The capillary line must be thermally insulated to avoid additional errors due to temperature influences on the capillary line.
- ◆ For application cases with constant ambient temperature, it is possible to design the measuring system for a certain capillary line temperature upon request.
- ◆ The additional error due to ambient temperature influence is for the majority of the measuring arrangements within the range $< 5\%$ of the span / 10 K.



Rigid Mount to the Stem
TSCh / TSChG

Case / ring	bayonet ring case stainless steel
Case filling	without / with
Nominal size	63, 100, 160, 250 (TSCh) mm
Stem	stainless steel 316Ti (1.4571)
Stem types	A1, A3, A4, A4.1, A5 or A6
Data sheet	8201



Rigid Mount to the Stem
TSChg / TSChgG

Case / ring	crimped-on ring case stainless steel
Case filling	without / with
Nominal size	63, 80, 100, 125, 160 mm
Stem	stainless steel 316Ti (1.4571)
Stem types	A1, A3, A4, A4.1, A5 or A6
Data sheet	8202

Gas-actuated Thermometers – Standard Range



Every Angle Turnable and Adjustable

TGeICh / TGeIChG

Case / ring	bayonet ring case stainless steel
Case filling	without / with
Nominal size	63, 100, 160 mm
Stem	stainless steel 316Ti (1.4571)
Stem types	A1, A3, A4, A4.1, A5 or A6
Data sheet	8211



Every Angle Turnable and Adjustable

TGeIChg / TGeIChgG

Case / ring	crimped-on ring case stainless steel
Case filling	without / with
Nominal size	63, 80, 100, 160 mm
Stem	stainless steel 316Ti (1.4571)
Stem types	A1, A3, A4, A4.1, A5 or A6
Data sheet	8212

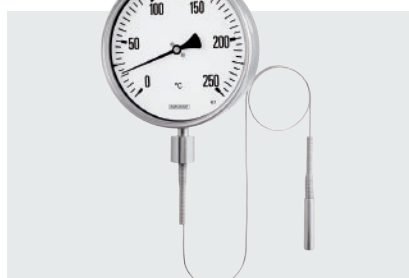
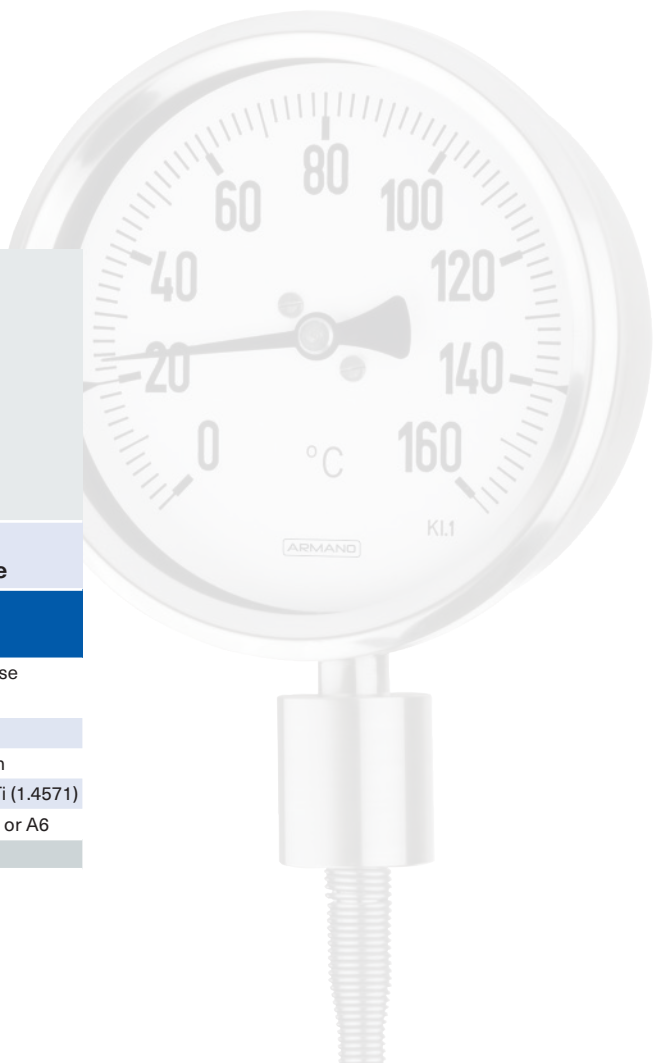

With Capillary Line to the Stem

TFCh / TFChG

Case / ring	bayonet ring case stainless steel
Case filling	without / with
Nominal size	63, 100, 160, 250 (TFCh) mm
Stem	stainless steel 316Ti (1.4571)
Stem types	A1, A3, A4, A5 or A6
Data sheet	8221



With Capillary Line to the Stem

TFChg / TFChgG

Case / ring	crimped-on ring case stainless steel
Case filling	without / with
Nominal size	63, 80, 100, 160 mm
Stem	stainless steel 316Ti (1.4571)
Stem types	A1, A3, A4, A5 or A6
Data sheet	8222



Square Thermometer for Switch Panels

TFQS

Case / ring	square case, front narrow rim black, clamp for switch panel mounting
Case filling	-
Nominal size	96x96, 144x144 mm
Stem	stainless steel 316Ti (1.4571)
Stem types	A1, A3, A4, A5 or A6
Data sheet	8225

Diesel Exhaust Thermometers

Diesel exhaust thermometers are primarily used for the measurement of exhaust and cooling water temperatures at diesel engines. They are gas-actuated thermometers, specially designed for high mechanical loads, among others due to the “stem in jacket version” and the standard case filling with highly viscous silicone oil. To increase their durability, diesel exhaust thermometers should always be applied in combination with solid drilled thermowells.

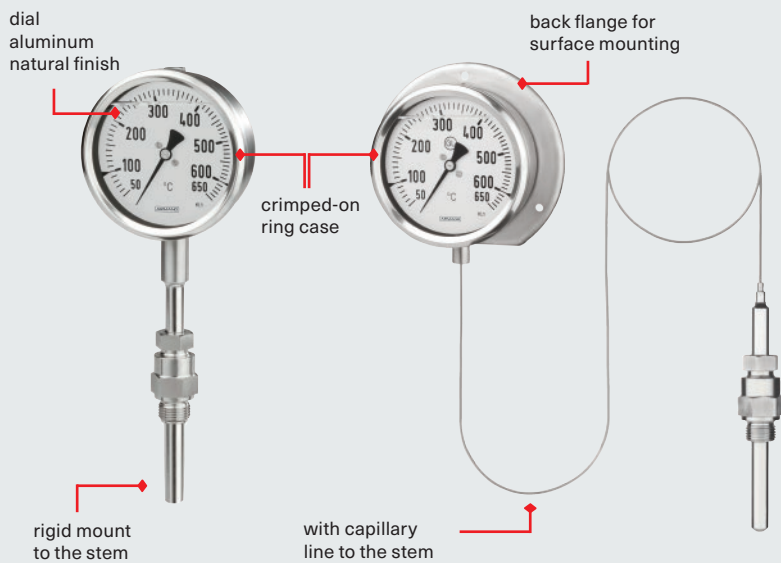

**Diesel Exhaust Thermometer
Rigid Mount to the Stem**

TAS

Case / ring	crimped-on ring case stainless steel
Nominal size	63, 80, 100 mm
Stem	stainless steel 316Ti (1.4571)
Stem types	A5.5, A1.5 or A3.5
Temperature ranges	0 – 120 °C 50 – 650 °C
Data sheet	8291



**Diesel Exhaust Thermometer
With Capillary Line to the Stem**

TAF

Case / ring	crimped-on ring case stainless steel
Nominal size	63, 80, 100 mm
Stem	stainless steel 316Ti (1.4571)
Stem types	A5.5, A1.5 or A3.5
Temperature ranges	0 – 120 °C 50 – 650 °C
Data sheet	8292

Ambient Temperature Thermometers

Ambient temperature thermometers are gas-actuated thermometers according to DIN EN 13190 and use the temperature-dependent pressure of a spatially enclosed quantity of gas as measure for the temperature. Our ambient thermometers are suitable for both indoor and outdoor application.



Ambient Temperature Thermometer

TRCh	
Case / ring	bayonet ring case stainless steel
Nominal size	100, 160 mm
Stem	stainless steel 316Ti (1.4571)
Temperature ranges	-40 / +40 °C -30 / +50 °C -20 / +60 °C
Data sheet	8293



How about a thermometer with individual design?

The instrument with high-quality stainless steel case is weatherproof and reliably indicates the temperature both indoors and outdoors.

Due to the latest technology, we are able to design your customised thermometer. We can implement individual dials with your colour requests, also combined with your text elements.



Example for outdoor wall mounting



Temperature Sensors (Stems)

Standard Stems for Gas-actuated and Bimetal Thermometers

A.. = stem for gas-actuated thermometers

B.. = stem for bimetal thermometers

L, L1 = stem length

La = active stem length

Specific values (see data sheets)

Information concerning the metrologically favourable selection can be found in the technical information sheet T08-000-031.

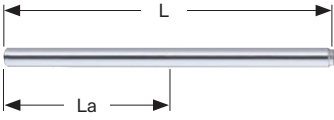
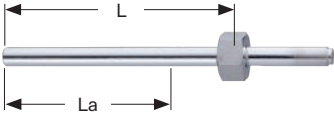
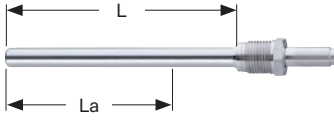
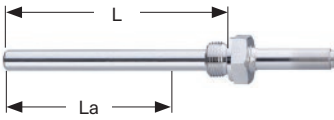
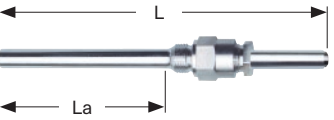
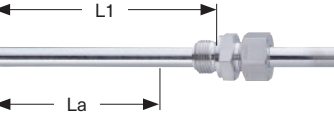
Stem type	A1, A1.5, B1	A3, A3.5, B3	A4, B4
Process connection	without screw fitting, plain stem	union nut	male thread, turnable thermowell required
			
Stem type	A4.1, B4.1	A5, A5.5, B5	A6, B6
Process connection	male thread, rigid	male thread, compression fitting adjustable at the plain stem	male thread, turnable / double male adapter
			

Special Stems for Gas-actuated Thermometers

Stem without bent tube – for difficult installation conditions and overlong thermowells

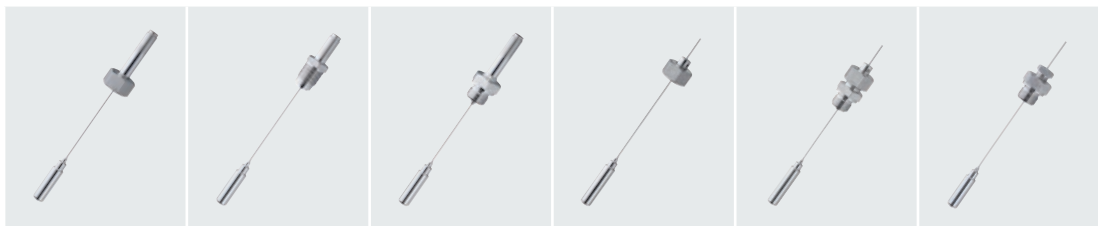





Stem type	A3.2	A4.2	A4.3	A2	A7	A7.1
Construction type	rigid mount with neck tube between thermometer and stem, capillary line between connection screw fitting and vessel (active length), capillary line wetted, if applicable			capillary line between thermometer and vessel (active stem length), compression fitting, turnable and movable at the capillary line, capillary line wetted, if applicable		
Material	stainless steel 316Ti (1.4571)			stainless steel 316Ti (1.4571)		
Vessel Ø	8, 10 or 12 mm			8, 10 or 12 mm		
Stem length L / capillary line length L _{FL}	L: 200 mm to 15 m			L _{FL} : 1 m to 15 m		
Process connection	union nut	male thread turnable	male thread rigid	union nut	male thread, turnable / double male adapter	male thread, clamping ring fitting, clamping connection at capillary line
Capillary line	stainless steel, Ø 2 mm			1 m, stainless steel, Ø 2 mm, bend protection to thermometer case		
Specifics	-	thermowell required	-	for application without thermowell not sealing, only for unpressurised media		clamping ring FKM (Viton®) medium temperature: max. 180 °C
Data sheet	8299.1			8299.2		

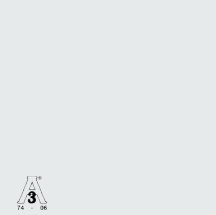

Temperature Sensors (Stems)

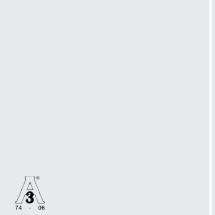
Special Stems for Gas-actuated Thermometers

For the application in food / bio / pharmaceutical industries, rigid mount to the stem, up to 400 °C

					
Stem type	A20.3	A20.1	A20.11	A20.12	A20.6
Construction type	for thermometers with rigid mount to the stem or for capillary line				
Material	stainless steel 316L (1.4435)				
Vessel Ø	10 or 12 mm				16 mm
Stem length L	30 mm to 200 mm				
Process connection ¹⁾	conical coupling and groove nut, DIN 11851	Clamp		Tri-Clamp	
		ISO 2852, for tubes according to ISO 2037 and BS 4825	DIN 32676, series A, for tubes according to DIN 11850	for tubes according to BS 4825 and O.D.-Tube, ASME BPE and ISO 1127	
Data sheet	8299.3				

Contact stem for temperature measurement at the outside of tanks and pipe barrels up to 300 °C

		
Stem type	A1.1	A1.2
Construction type	for thermometers with rigid mount to the stem or with max. 5 m capillary line	
Material	stainless steel 316Ti (1.4571)	
Stem length	90 mm	
Stem width	approx. 20 mm	approx. 24 mm
Contact surface	plain	concave
Data sheet	8299.4	

¹⁾ other process connections, e.g. aseptic liner DIN 11864-1, form A, stem type 20.2 upon request

Thermowells

Connection Between Thermometer and Process

Thermowells separate the temperature sensor from the medium and protect it against mechanical and corrosive stress. Depending on the construction type, they also allow a replacement of the thermometers during operation.

We provide thermowell solutions for almost all industries; from sterile process technologies to chemical as well as petrochemical industries to high-temperature applications in power stations or waste incineration plants – we will find the ideal solutions concerning material, construction type or coating.

Our standard range includes solid-drilled and fabricated thermowells according to DIN, fabricated thermowells for food / bio / pharmaceutical industries and versions with clamp fitting at the temperature sensor. Other versions and customer-specific solutions are available upon request.

Construction and Metrological Information

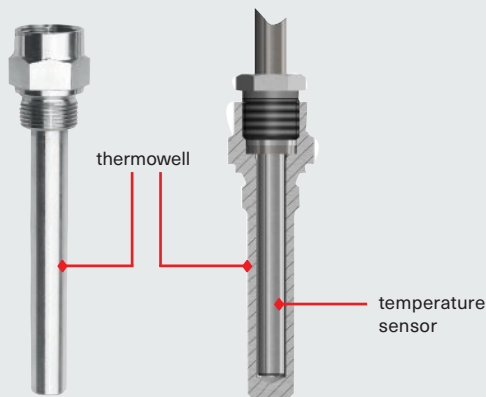

- ◆ The application of thermowells increases the response time of thermometers, mainly due to the gap between thermowell and thermometer stem.
- ◆ For most of the application cases, this fact is not relevant since temperature processes usually proceed slowly. Only in case of sudden, abrupt temperature changes, the adjustment time to the medium temperature has to be increased accordingly.
- ◆ For the reduction of the response time, the application of heat transfer paste has proved to be successful.

We carry out a thermowell calculation for your specific case of application.

More Safety with Calculation for Your Specific Case of Application

Thermowells are mechanically highly stressed components. With special calculations, we can determine whether the thermowell geometry and the material meet the specific operating conditions.

A completely filled in checklist for the thermowell calculation¹⁾ with all necessary application data is required.

The certificate includes:

- ◆ Thermowell data
- ◆ Application and calculation data
- ◆ Calculation according to DIN 43772 / ASME PTC 19.3 or according to DIN 43772 with load diagram upon request

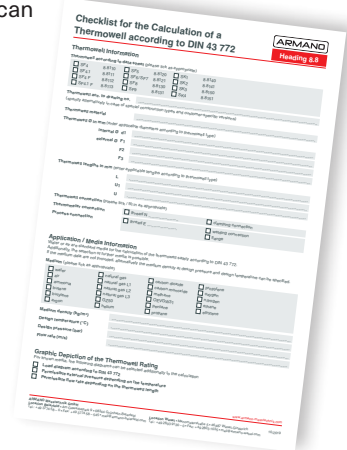

¹⁾ The checklist is available for download on our website.

Thermowells

Materials and Coatings

Materials

Depending on the process, a wide range of materials are applied to meet the demands on temperature resistance, mechanical strength and chemical resistance. Additionally, we provide particularly economic, material-saving construction types for special materials. There, only the wetted parts of the thermowell are made of the special material, e.g. tantalum coating sleeves or welded flange thermowells with sealing face insert.

Coatings

A coating is a method to achieve an increased corrosion resistance. In special processes, the wetted part of the thermowell is coated, generally with polymers such as PTFE or ECTFE.

Class of Materials for Thermometer Thermowells

Standard	
stainless steel grades	e.g. 1.4571 or 1.4404
creep-resistant steel grades	13CrMo44
Upon request	
duplex and super duplex steels	e.g. 1.4462, 1.4501
heat-resistant steel grades	e.g. 1.4841, 1.4762, 1.4876
creep-resistant steel grades	e.g. 16Mo3, 10CrMo9-10
nickel-base alloys	e.g. various Monel, Hastelloy, Inconel grades
other materials	e.g. titanium or tantalum (as coating sleeve)

Certificates

We Issue the Following Certificates Upon Request

- ◆ Test certificate 2.1, 2.2 and 3.1 according to EN 10204
- ◆ Special and material tests available upon request
- ◆ Non-destructive weld inspections
- ◆ Pressure tests
- ◆ Upon request, we issue the test certificate 3.2 according to EN 10204



Thermowells – according to DIN 43772



Thermowell model		SF4	SF4.1	SF4F	SF4.1F
Form (DIN 43772)		4	-	4F	-
Construction type	solid drilled ¹⁾	✓	✓	✓	✓
	fabricated	-	-	-	-
Material (standard) ²⁾		stainless steel 316Ti (1.4571), 1.7335 (13 CrMo 4-5)		stainless steel 316Ti (1.4571)	
Process connection		weld-in		with flange	
Connection to the stem		female thread	male thread	female thread	male thread
Suitable stem type	standard	A4, A4.1, A5, A5.5, A6, B4, B4.1, B5, B6	A3, A3.5, B3	A4, A4.1, A5, A5.5, A6, B4, B4.1, B5, B6	A3, A3.5, B3
	special	A4.2, A4.3, A7, A7.1	A3.2, A2	A4.2, A4.3, A7, A7.1	
Data sheet		8.8110	8.8111	8.8112	8.8113



Thermowell model		SF5	SF6 / SF7	SF8	SF9
Form (DIN 43772)		5	6, 7	8	9
Construction type	solid drilled ¹⁾	-	✓	-	✓
	fabricated	✓	-	✓	-
Material (standard) ²⁾		stainless steel 316Ti (1.4571), 2.0401 (brass)	stainless steel 316Ti (1.4571), 1.7335 (13 CrMo 4-5)	stainless steel 316Ti (1.4571)	stainless steel 316Ti (1.4571), 1.7335 (13 CrMo 4-5)
Process connection		male thread			
Connection to the stem		female thread		male thread	
Suitable stem type	standard	A4, A4.1, A5, A5.5, A6, B4, B4.1, B5, B6		A3, A3.5, B3	
	special	A4.2, A4.3, A7, A7.1		A3.2, A2	
Data sheet		8.8120	8.8121	8.8130	8.8131

¹⁾ thermowell and screw fitting made of solid; flanges are welded to the thermowell
²⁾ others upon request

Thermowells – Special



Thermowell model		SK1	SK2	SK3.B	SK4.B
Form (DIN 43772)		based on DIN 42772 form 5	based on DIN 42772 form 6, 7	-	-
Construction type	solid drilled ¹⁾	-	✓	-	✓
	fabricated	✓	-	✓	-
Material (standard) ²⁾		stainless steel 316Ti (1.4571)			
Process connection		male thread			weld-in
Connection to the stem		clamping ring fitting for plain stems		lateral retaining screw for plain stems	
Suitable stem type	standard	A1, A1.5 B1		B1	
	special	-		-	
Data sheet		8.8140	8.8141	8.8150	8.8151



Thermowell model		SL1	SL11	SL12	SL3	SL6
Form (DIN 43772)			-		-	-
Construction type	solid drilled ¹⁾		-		-	-
	fabricated		✓		✓	✓
Material (standard) ²⁾		stainless steel 316L (1.4435)				
Process connection ³⁾		ISO 2852, for tubes according to ISO 2037 and BS 4825	Clamp connection DIN 32676, series A, for tubes according to DIN 11850		Tri-Clamp for tubes according to BS 4825 and O.D.-Tube, ASME BPE and ISO 1127	conical coupling and groove nut DIN 11851 Varivent® for Varinline® case
Connection to the stem		male thread				
Suitable stem type	standard	A3 B3				
	special	A2				
Data sheet		8.8160				

¹⁾ thermowell and screw fitting made of solid
²⁾ others upon request

³⁾ other process connections, e.g. SL2, aseptic liner DIN 11864-1,
form A upon request

Machine-glass Thermometers

Machine-glass thermometers according to DIN EN 16195 are based on the temperature-dependent expansion of a fluid. The measuring system is located in the robust metal case and consists of a liquid-filled vessel with connected glass capillary. The liquid level in the scaled glass capillary indicates the temperature.

Construction and Versions

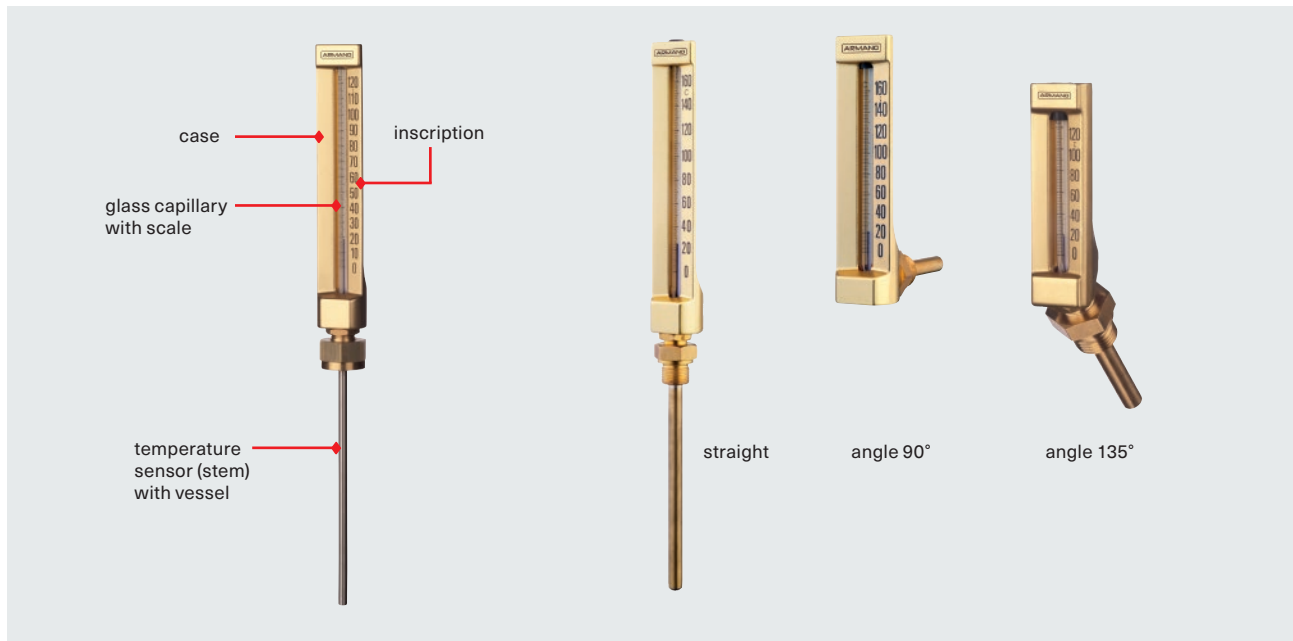

Type	A	B	C	C	C
Dimension	110 x 30 mm	150 x 36 mm	200 x 36 mm	200 x 36 mm	200 x 36 mm
Stem type	2	2	2	3	4
Male thread ¹⁾	✓	✓	✓	-	-
Union nut ¹⁾	-	-	-	✓	✓ (only M24x1.5)
Installation length L1	from 30 mm onwards	from 63 mm onwards	from 63 mm onwards	from 89 mm onwards	from 155 mm onwards
Stem material	brass	brass	brass	St 35, fitting brass	St 35, fitting brass
Stem Ø	10 mm	10 mm	10 mm	10 mm	6.5 mm
Construction type	V (straight)	VA2	VB2	VC2	VC4
	H (angle 90°)	HA2	HB2	HC2	HC4
	S (angle 135°)	SA2	SB2	SC2	SC4
T-sheet	T08-000-020	T08-000-026	T08-000-027	T08-000-028	T08-000-029

¹⁾ available threads see T-sheet

Additional Electrical Accessories

Available Thermometers with Additional Electrical Accessory

Additional electrical accessories can be integrated in temperature measuring instruments. Limit switch contact assemblies close or open electric or pneumatic circuits. The limit setting pointers can be adjusted to the required value on the entire range of the scale. When exceeding or falling below the adjusted reference value, the actual value pointer triggers the switch.



TSCh / TSChOe¹⁾

Case / ring bayonet ring case
stainless steel

Nominal size 100, 160 mm

Additional electrical accessory type M, I, E

Data sheet 8201.90



TGeCh

Case / ring bayonet ring case
stainless steel

Nominal size 100, 160 mm

Additional electrical accessory type S / M, I, E, P

Data sheet 8211.90



TFCh / TFChOe¹⁾

Case / ring bayonet ring case
stainless steel

Nominal size 100, 160 mm

Additional electrical accessory type M, I, E

Data sheet 8221.90

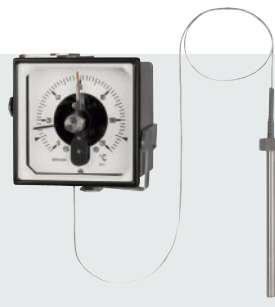

TFQS

Case / ring square case
narrow front ring black
clamp for switch panel
mounting

Nominal size 96x96, 144x144 mm

Additional electrical accessory type S / M, I, E, P

Data sheet 8225.90



TRCh

Case / ring bayonet ring case
stainless steel

Nominal size 100, 160 mm





Additional electrical accessory type S / M, I, E

Data sheet 8293.90





¹⁾ Please regard the information on the specific version in the respective data sheets.

Accessories





According to DIN 43772

					
Type	HR	S2	AV1	AV2	S1
Application	neck tube e.g. for bridging insulating material	welding piece process connection for weld-in thermowells	connection screw fitting stem A3 / B3	connection screw fitting stem A4 / B4 A4.1 / B4.1	welding piece stem A4 / B4 A4.1 / B4.1 threaded thermowells
Material	stainless steel 316Ti (1.4571)				
Data sheet	8.8301	8.8301	8.8201	8.8201	8.8201

Limit Switch Contact Assemblies

				
Type	S or M	I	E	P
	direct (electromechanical)	indirect (contact-free)	indirect (contact-free)	indirect (contact-free)
	low-action or magnetic contact	inductive limit switch contact assembly	electronic limit switch contact assembly	pneumatic limit switch contact assembly
Data sheet	9.1000	9.1000	9.1000	9.1000

Accessories for Limit Switch Contact Assemblies

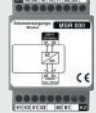
					
Type	MSR	MSR-I	KF..-SR2..	KHA6-SH-Ex1	MSR 000
	pulse controlled multifunctional relay	pulse controlled multifunctional relay	switch amplifier - intrinsically safe -	switch amplifier - intrinsically safe -	power supply module - not intrinsically safe -
	for limit switch contact assemblies S and M	for inductive limit switch contact assemblies	for inductive limit switch contact assemblies	for inductive limit switch contact assemblies safety switching	
Data sheet / T-sheet	9521	9531	9532	T09-000-041	9981

General Installation Information

Installation Examples for Thermometer Stems

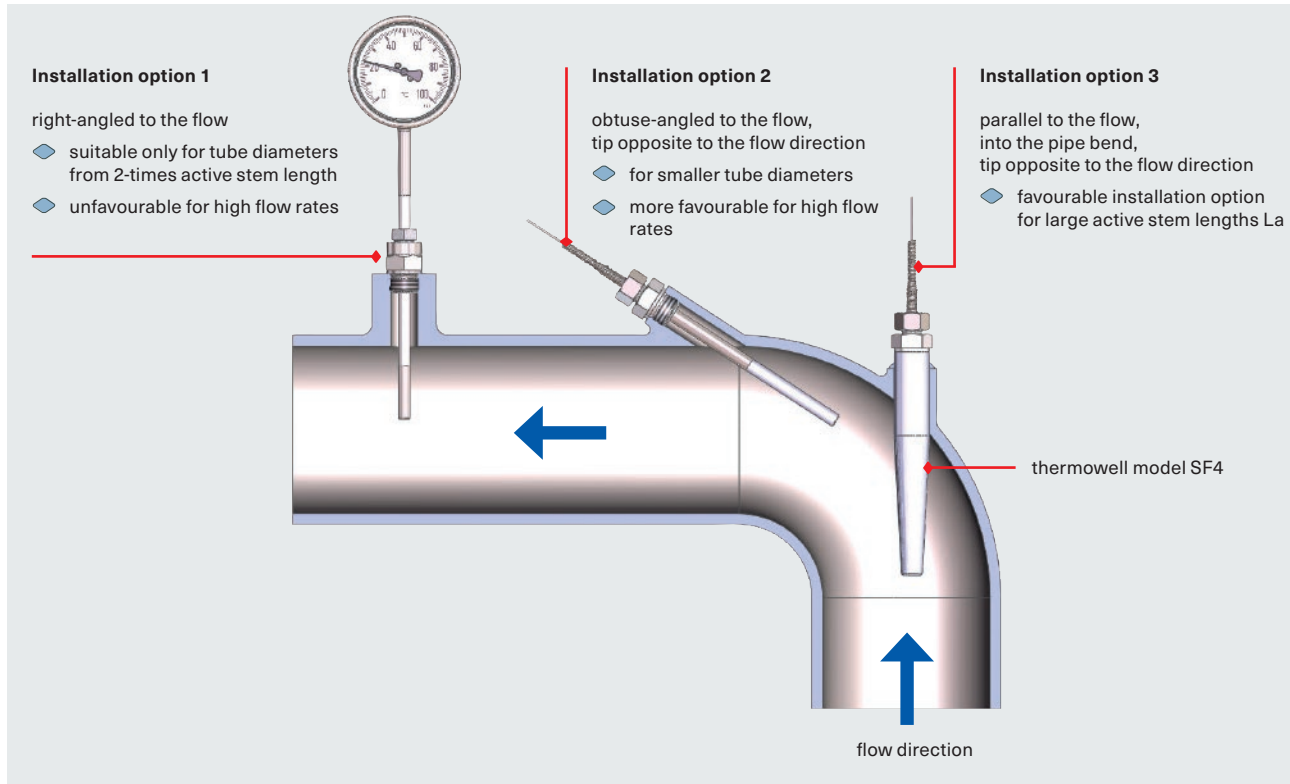

Important for the Design

- ◆ Active stem length L_a (see data sheets)
- ◆ Maximum values for the process pressure and process temperature
- ◆ Type of medium
- ◆ Flow rate and density of the medium
- ◆ Metrological aspects (see T08-000-031)



ARMANO

ARMANO Messtechnik GmbH

Location Beierfeld

Am Gewerbepark 9
08344 Grünhain-Beierfeld
Germany

Tel.: +49 3774 58 - 0

Fax: +49 3774 58 - 545

mail@armano-beierfeld.com

Location Wesel

Manometerstraße 5
46487 Wesel-Ginderich
Germany

Tel.: +49 2803 9130 - 0

Fax: +49 2803 1035

mail@armano-wesel.com

Subsidiary Company

ARMANO Instruments, Inc.

14900 Woodham Drive, Suite A-150
Houston, Texas 77073
USA

Tel.: +1 281 982 3333

mail@armano-instruments.com

www.armano-instruments.com

Copyright© 2023 · Overview 8000 – Temperature Measurement – Mechanical Temperature Measuring Instruments (Version 10/23)

Concept, Design and Realisation: ARMANO Messtechnik GmbH · Picture credits: www.stock.adobe.com
Technical changes, replacement of materials and printing errors excepted!