

Dead Weight Testers

Hydraulic version

Pressure ranges 0.25 – 60 bar and 0.25 – 100 bar

PD 60

PD 100

Application

- High-precision primary standard (comparison standard)
- Reference device for calibration services, gauging offices and laboratories
- Suitable for testing, adjusting and calibrating pressure measuring instruments without using an external reference device

Construction

The main components are measuring system, valve units, spindle unit for fine adjustment of the pressure and set of weights. The measuring system consists of a fine lapped piston / cylinder pair. The weight-loaded piston is pressed down by the local gravitation of the weights. From below the test pressure, which is generated and adjusted by the spindle pump, acts towards the piston surface area. This test pressure is increased until the hydraulic force of the medium on the piston surface area (acting from below) compensates the weight force of the piston / weight system and the equilibrium of forces is reached. During this state of equilibrium, the piston floats freely in the cylinder.

In order to simplify the handling, the weights are already standardised to the specific determined piston surface area and the local gravitation at the installation site. The set of weights is available discreetly graduated in different pressure units (bar, Pa, psi).

Piston and weights are kept rotating with a motor while floating in order to minimise the influence of static friction of piston and cylinder and therefore to guarantee a sensitive discrimination threshold.

The dead weight testers described herein operate in a range from 0.25 to 60 bar or 0.25 to 100 bar, depending on the model.

Specialties

Due to the high accuracy of the dead weight tester, the influence of the gravitational acceleration is not negligible. A requirement for an official verification is the calibration of the dead weight tester with the gravitational acceleration at the installation site. Thus, this value needs to be specified when placing the order. A calibration for the installation site is recommended without official verification as well.

Without specification of the gravitational acceleration, the dead weight tester is calibrated with the value at the manufacturing site ($g_{Hst} = 9.80968 \text{ m/s}^2$). Then, the measuring values need to be converted at the installation site for the compliance with the accuracy class.

Standard Versions

Set of Weights

In bar / MPa

Pressure Range	PD 60	PD 100
Basic load	0.25 bar	0.25 bar
Main measuring range	10 – 60 bar	10 – 100 bar
Required admission pressure air	6 bar	6 bar

Reference Condition for the Guaranteed Accuracy

Ambient temperature +20 °C ±2 °C (+68 °F ±3.6 °F)

barotec®
KALIBRIERTECHNIK



Accuracy (factory calibration)

Standard ±0.05 % of the measured value¹⁾

Medium

Special oil

Nominal Piston Cross-section

0.5 cm²

Rotation of the Weights

By electric drive (230 – 240 V AC / 50 Hz / 3 W)

Connection

Male G $\frac{1}{2}$ LH with clamping sleeve for G $\frac{1}{2}$ right and M 20x1.5 right, incl. double sealing

Connection for External Compressed Air

Plug connection (Prestolock) for PA hose N 4x1, with adapter for N 6x1

Case

Aluminum case, grey enamelled (self-supporting cover), 3 adjustable feet for precise horizontal alignment according to integrated circular level

Case Dimensions incl. Star Handle (L x W x H)

PD 60 490 x 480 x 330 mm (19.29 x 18.9 x 12.99")
PD 100 490 x 480 x 400 mm (19.29 x 18.9 x 15.75")

Approx. Weight

	PD 60	PD 100
Dead weight tester	27 kg (59.52 lb)	28 kg (61.73 lb)
Set of weights	36 kg (79.37 lb)	57 kg (125.66 lb)
Device packaging	21 kg (46.3 lb)	21 kg (46.3 lb)
Transport case set of weights	9.2 kg (20.28 lb)	9.2 kg (20.28 lb)

¹⁾ in the main measuring range, the accuracy refers to the measured value; in the secondary measuring range, it refers to 10 bar

Technical Drawings

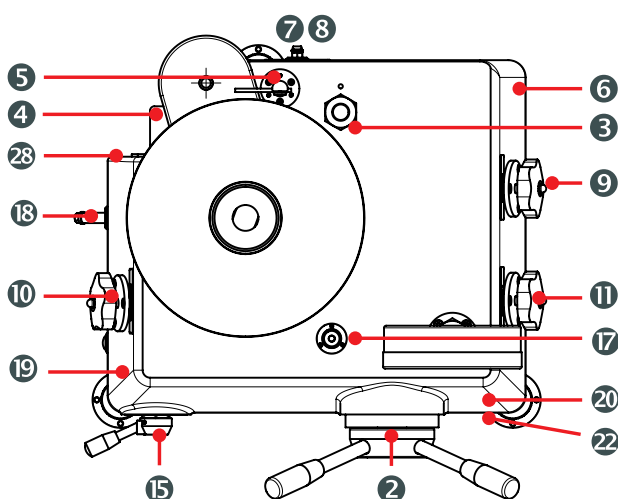
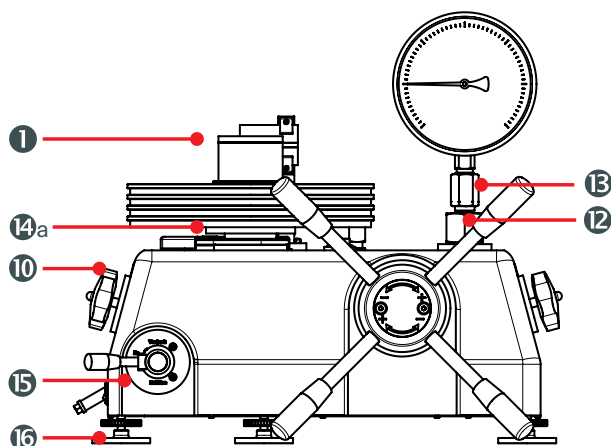

Schematic Drawing

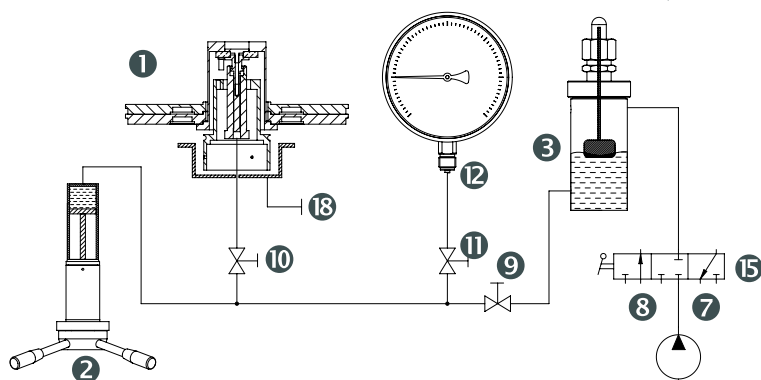

- | | | |
|---|--|---|
| 1 Measuring system | 10 Stop valve "Measuring system / Messsystem" | 16 Adjustable feet |
| 2 Spindle pump with star handle | 11 Stop valve "Test connection / Prüfanschluss" | 17 Circular level |
| 3 Oil reservoir | 12 Test connection | 18 "Oil drain / Ölablass" (overflow of the system) |
| 4 Electric drive | 13 Clamping sleeve (AF 27) | 19 Switch electric drive |
| 5 Reading device (mirror) | 14 Base plate (basic load) | 20 Calibration plate (for accredited calibration) |
| 6 Case | 14a Ring weight base plate | 22 Nameplate |
| 7 "Connection admission pressure / Anschluss Vordruck" | 15 Change-over valve for external admission pressure ("Admission pressure / Vordruck", "Closed / Zu", "Vent / Entlüften") | 28 C14 inlet |
| 8 "Ventilation admission pressure / Entlüftung Vordruck" | | |
| 9 Valve "Pressure compensation / Druckausgleich" | | |

Options

- Inspection certificate 3.1 according to DIN EN 10204 on the accuracy
- Accredited calibration or DKD approval¹⁾
- Hose N 4x1 for Prestolock

Special Versions Upon Request

- Set of weights in kp/cm^2 , psi; other weights
- Adapters for other connection threads
- Higher accuracy 0.02 %

Scope of Delivery

The delivery includes – in addition to the dead weight tester and the set of weights in a transport case:

- 1 operating instruction
- 1 l special oil (medium)
- 1 protective cover
- 1 clamping sleeve $G\frac{1}{2}$ (mounted)
- 1 clamping sleeve $M20 \times 1.5$
- 1 special gasket for test item, with 2 encased O-rings
- 4 O-rings as spare parts
- 2 adapters for $N6 \times 1$ (admission pressure connection)
- 1 plug for oil drain (mounted)
- 1 mains cable

Ordering Information

Please specify in your order:

Basic model PD 100
Options see options

Example PD 100
 accuracy 0.05 %
 adapter $\frac{1}{2}$ " NPT
 gravity acceleration at the installation site
 test report 2.2

¹⁾ see section Specialties